

Spannzange / collet ER32 DIN6499
 Spannbereich / clamping range: 2,0 - 20,0

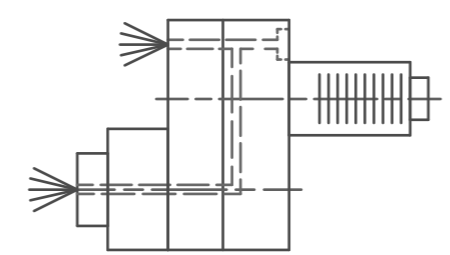

Innen- und Aussenkuehlung / Inside and outside coolant supply
 Kein Trockenlauf / No dry run
 Kuehmittelfiltrierung 50μ / coolant filtration 50μ

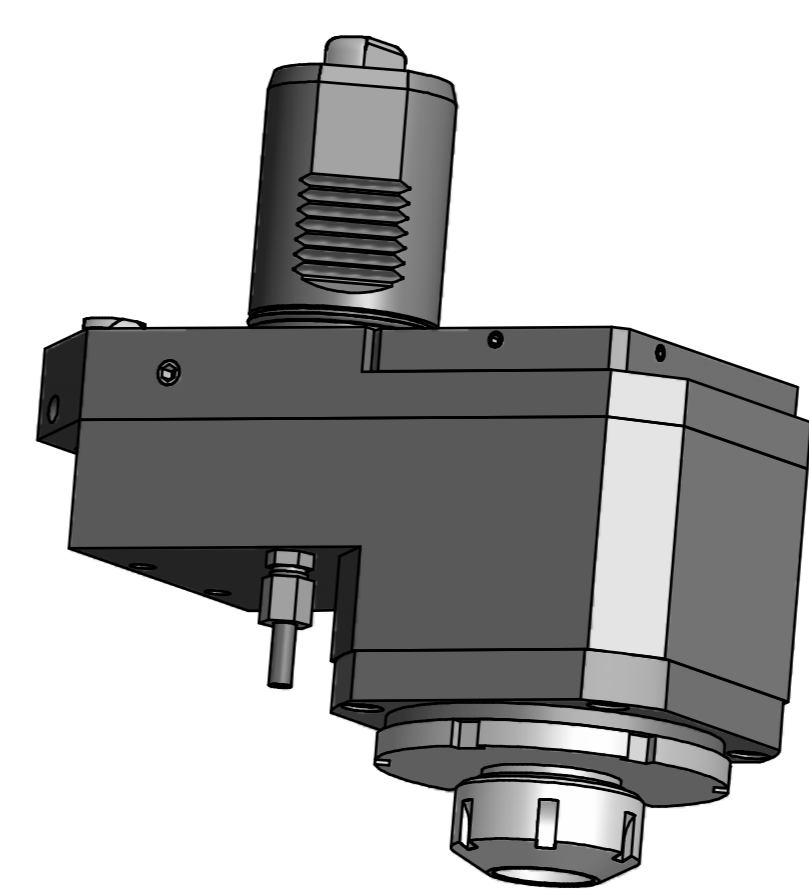
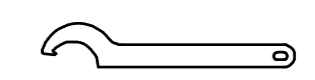

 Hakenschlüssel
 mit Nase
 Hook wrench with
 nose end
 DIN1810 A 80x90

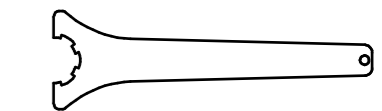
 Spannzangenschlüssel
 Clamping wrench
 232

Copyright **EWS Tool Technologies**
 Weitergabe und Vervielfaeltigung dieser Unterlage,
 Verwertung und Mitteilung ihres Inhalts nicht
 gestattet, soweit nicht ausdruercklich zugestanden.
 Zuwiderhandlungen verpflichten zu Schadenersatz.

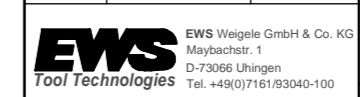
Bemerkung - Note Nicht ohne Kuehlmittel betreiben! <i>Not for use without coolant-Fluid!</i>	Technische Daten - Technical data M1 / M2 = 100 / 100 Nm n1 / n2 = 4000 / 4000 1/min i (N1:N2) = 1:1 Dmax = 70 bar	Benennung - Title Axial Bohr u. Fräskopf achsversetzt Ax. drill. and mill. head offset	name 08.03.2007	date 08.03.2007	Technische Aenderungen vorbehalten! Subject to technical modifications! Nr. 50.5032SQT28RIK MNR: 120726 IDENT: D-EWS-014288 - Blatt - page 1 (1)
			 EWS Werkzeug GmbH & Co. KG Maybachstr. 1 D-72066 Ehingen Tel. +49(0)716193040-100		