

Spannzange / collet ER40 DIN6499
 Spannbereich / clamping range: 3,0 - 26,0

Gewindebohrzange / tapping collet
 ET-1-40 M6-M16

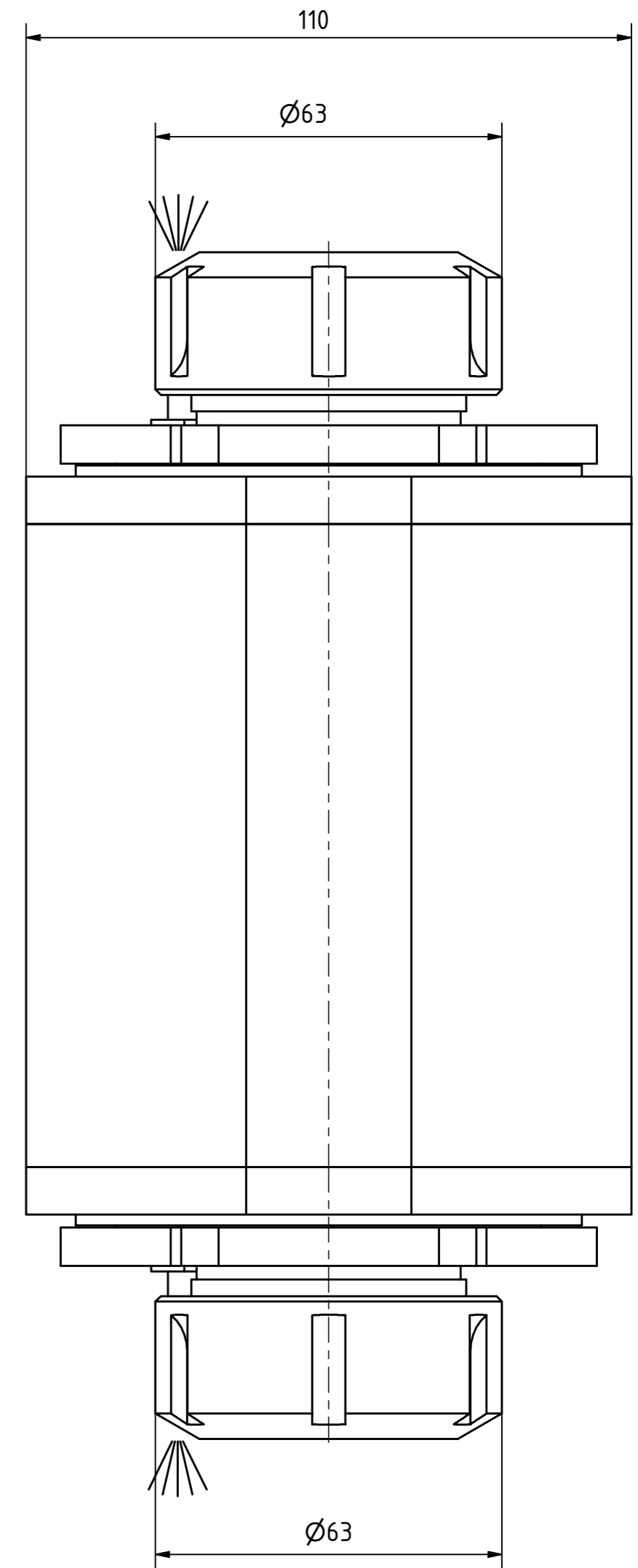

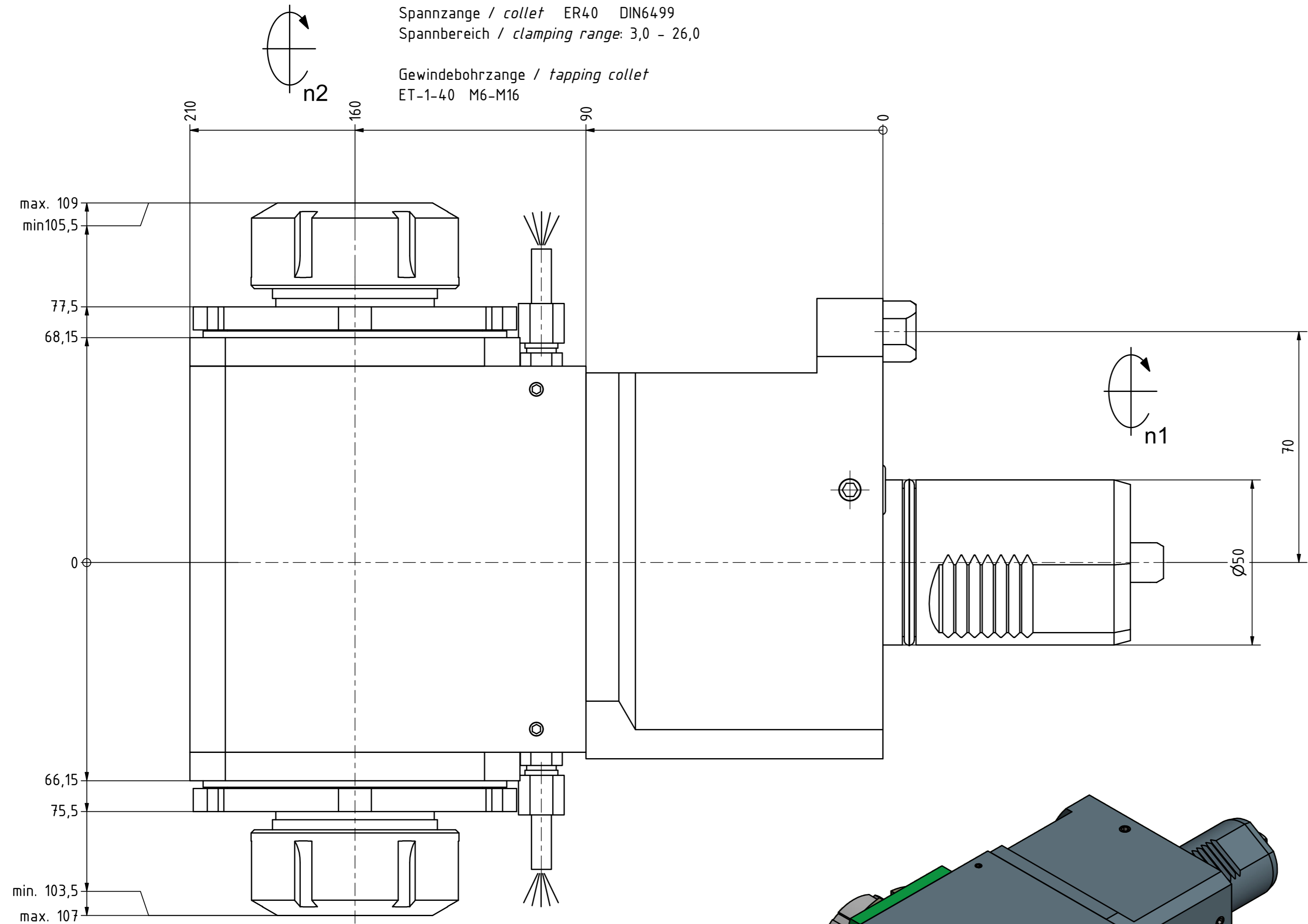

Spannzange / collet ER40 DIN6499
 Spannbereich / clamping range: 3,0 - 26,0

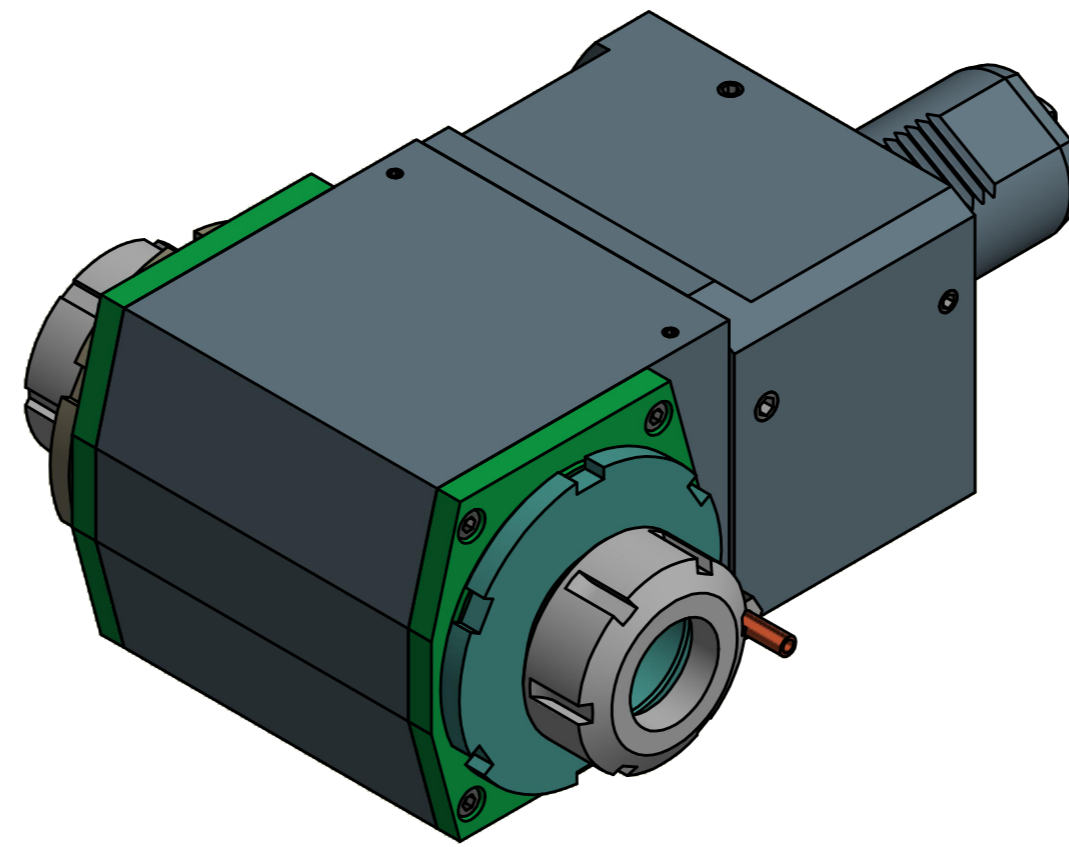
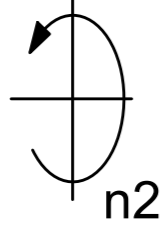
Gewindebohrzange / tapping collet
 ET-1-40 M6-M16

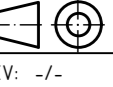

Copyright **EWS Tool Technologies**
 Weitergabe und Vervielfältigung dieser Unterlage,
 Verwertung und Mitteilung ihres Inhalts nicht
 gestattet, soweit nicht ausdrücklich zugestanden.
 Zuwiderhandlungen verpflichten zu Schadenersatz.

Bemerkung - Note	Technische Daten - technical data Weight = 19,011 [kg] Torque max. (M1/M2) = 200 / 2000 [Nm] Speed max. (n1/n2) = 4000 / 4000 [rpm] Gear ratio (i)=n1:n2 [1/1] 1:1	Benennung - Title Radial Bohr und Fräskopf Radial drilling and milling head	 EWS Weigle GmbH & Co. KG Maybachstr. 1 D-73066 Ulm/ingen www.ews-tools.de Technische Änderungen vorbehalten! Subject to technical modifications! IDENT: D-EWS-067154 Nr. - No. 60.5040DSQT28	 MNR REV: -/- 122661 
------------------	--	---	---	---