

Spannzange / collet ER40 DIN6499
 Spannbereich / clamping range: 3,0 - 26,0

Gewindebohrzange / tapping collet
 ET-1-40 M6-M16

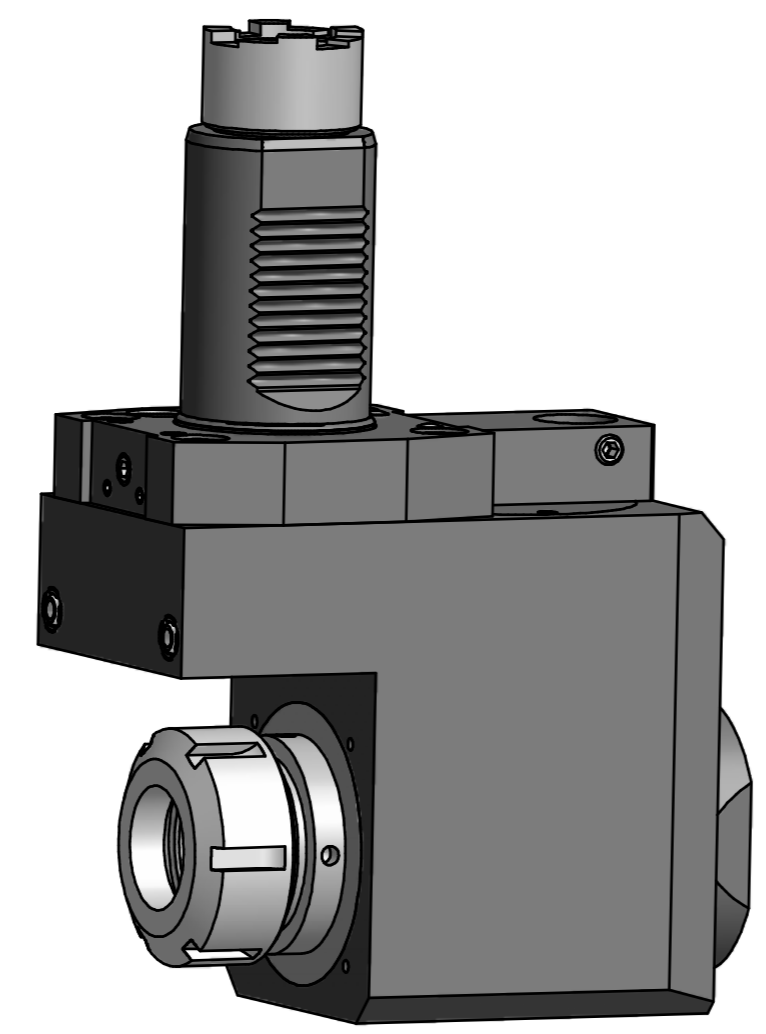
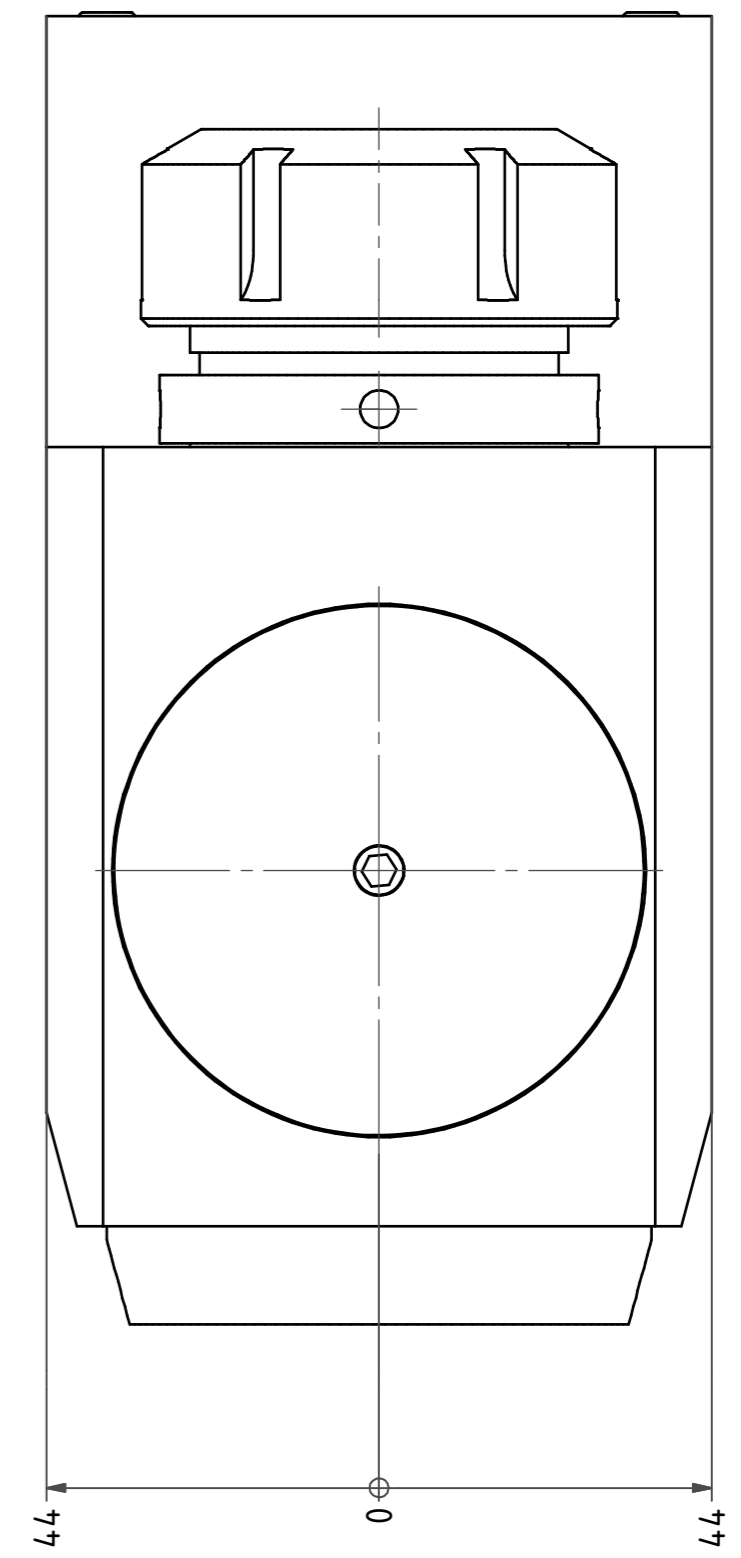
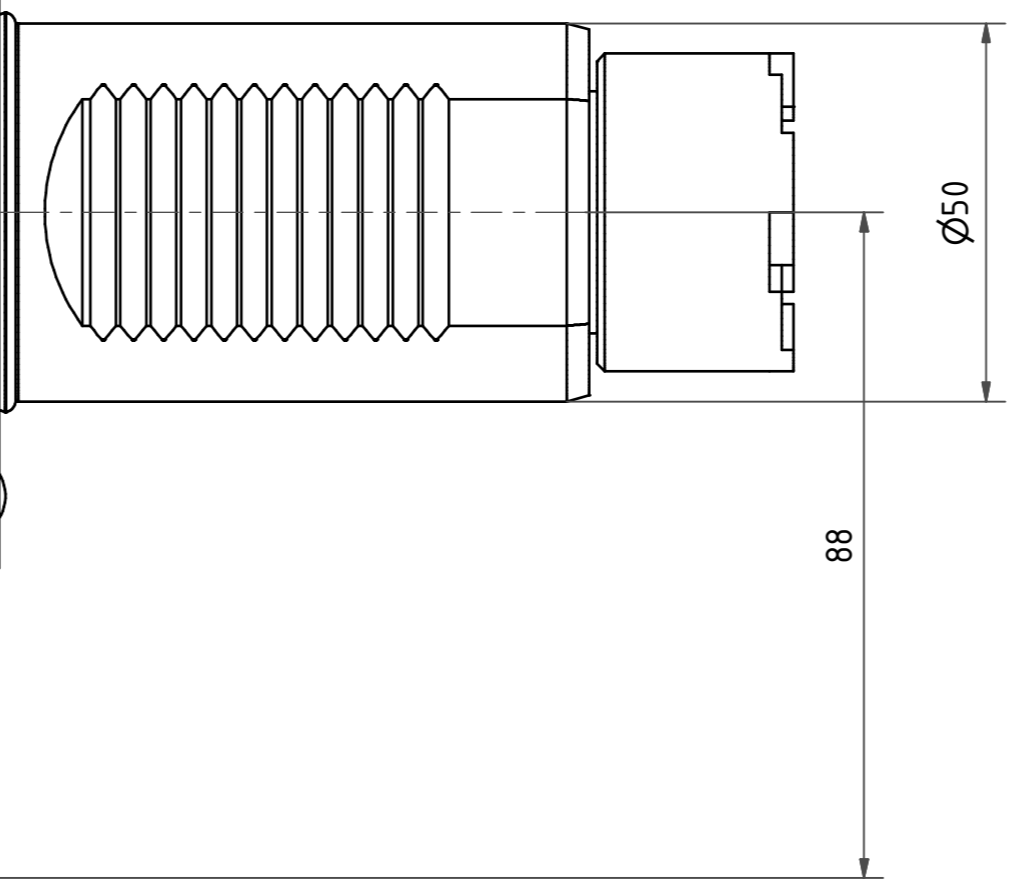

Hakenschlüssel
 mit Zapfen
 Hook wrench
 with fixed pin
 DIN1810 B 58x62

Spannzangenschlüssel
 Clamping wrench
 240

Copyright **EWS Tool Technologies**
 Weitergabe und Vervielfältigung dieser Unterlage,
 Verwertung und Mitteilung ihres Inhalts nicht
 gestattet, soweit nicht ausdrücklich zugestanden.
 Zuwiderhandlungen verpflichten zu Schadenersatz.

Benennung - Title	Technische Daten - Technical data		Benennung - Title	name	date	Technische Änderungen vorbehalten! Subject to technical modifications!
	M ₁ / M ₂ = 80 / 80 Nm n ₁ / n ₂ = 4000 / 4000 1/min i (N ₁ :N ₂) = 1:1					
Benennung - Note				drawing	09.03.2007	
			EWS EWS Werkzeug GmbH & Co. KG Mühlbacherstr. 1 D-73066 Ulm/lingen Tel. +49(0)7161/93040-100		DIN A2	
			MNR: 120719		IDENT: D-EWS-014104 - Blatt - page 1 (1)	