

Spannzange / Collet ER16 DIN6499
 Spannungsbereich / Clamping range: 1,0 - 10,0

Gewindebohrzange / Tapping Collet
 ET-1-16 M1-M6

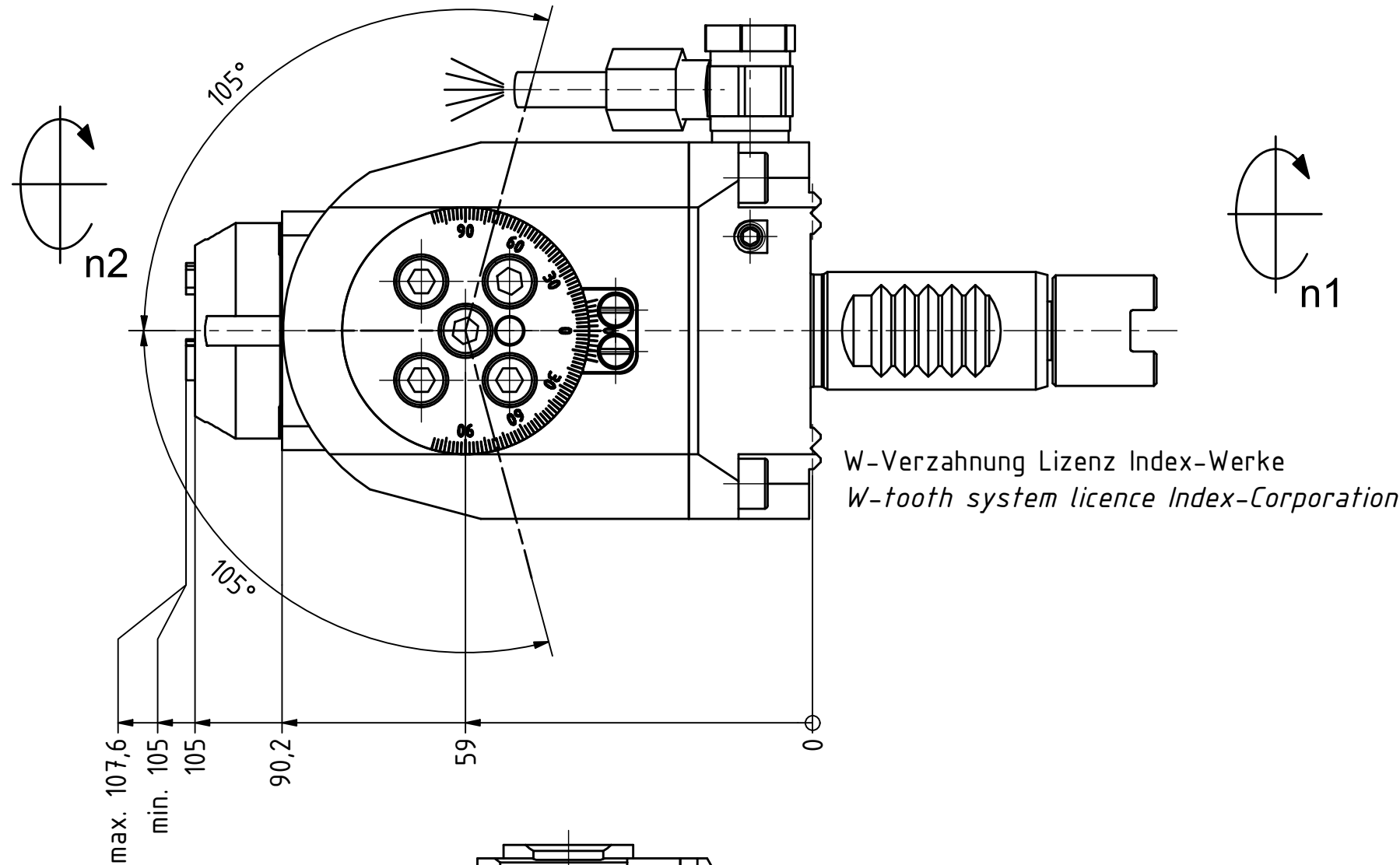

W-Verzahnung Lizenz Index-Werke
 W-tooth system licence Index-Corporation

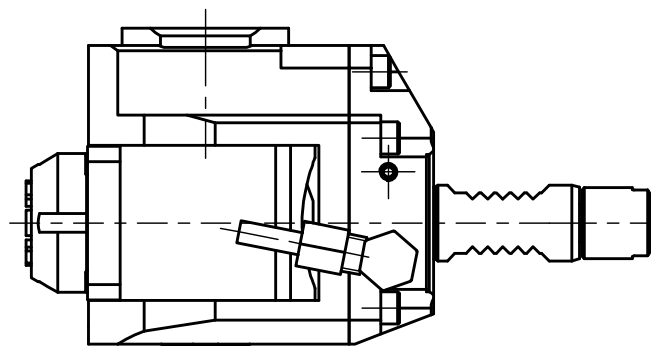
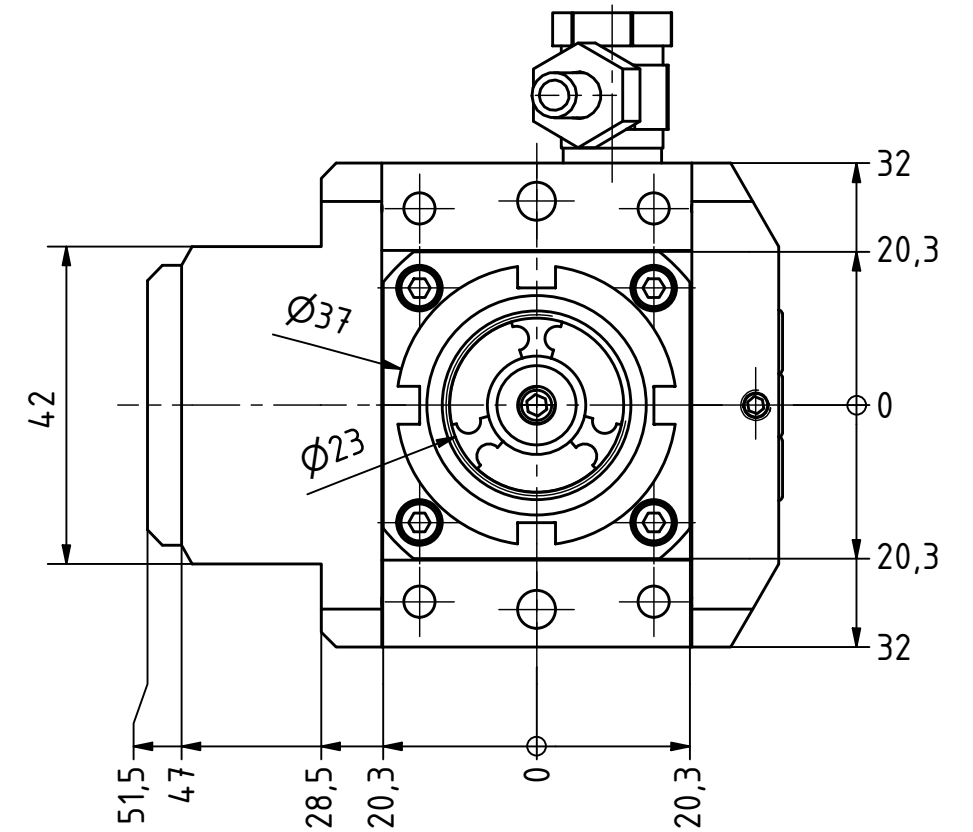

Doppelverzahnung Lizenz Traub
 double tooth system licence Traub

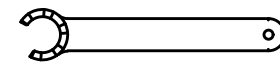
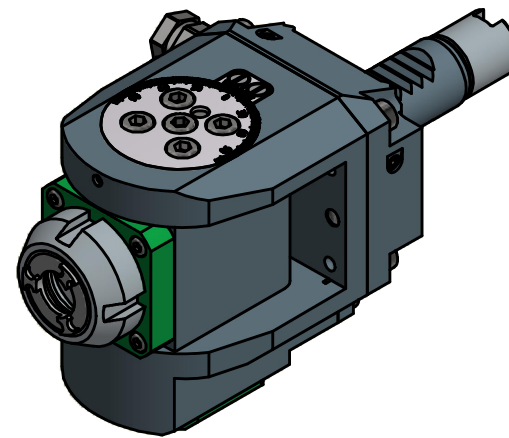

Spannzangenschlüssel für
 innenliegende Mutter
 Clamping wrench for
 internal collet
 216AX

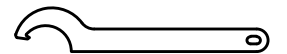

Hakenschlüssel
 mit Nase
 Hook wrench with
 nose end
 DIN1810 A 36x38

Eine Nachbarstation ist nicht verwendbar!
 One neighbour station is not useable!

Copyright **EWS Tool Technologies**
 Weitergabe und Vervielfaeltigung dieser Unterlage,
 Verwertung und Mitteilung ihres Inhalts nicht
 gestattet, soweit nicht ausdrecklich zugestanden.
 Zuwiderhandlungen verpflichten zu Schadenersatz.

Bemerkung - Note Technische Daten - technical data Weight = 2.442 [kg] Torque max. (M1/M2) = 11 / 11 [Nm] Speed max. (n1/n2) = 8000 / 8000 [1/min] Gear ratio (i)=n1:n2 = 1:1	Benennung - Title Schwenkkopf Swivel head	 EWS Weigle GmbH & Co. KG Maybachstr. 1 D-73066 UHINGEN www.ews-tools.de Technische Aenderungen vorbehalten! Subject to technical modifications! IDENT: DEWS142767 Nr. - No. 63.2016C100RLWIM	 REV: -/C MNR. 153786	
--	---	---	--	---