

6 | 5 | 4 | 3 | 2 | 1

D
C
B
A

Schwenkbereich ±105°
Swivel area ±105°

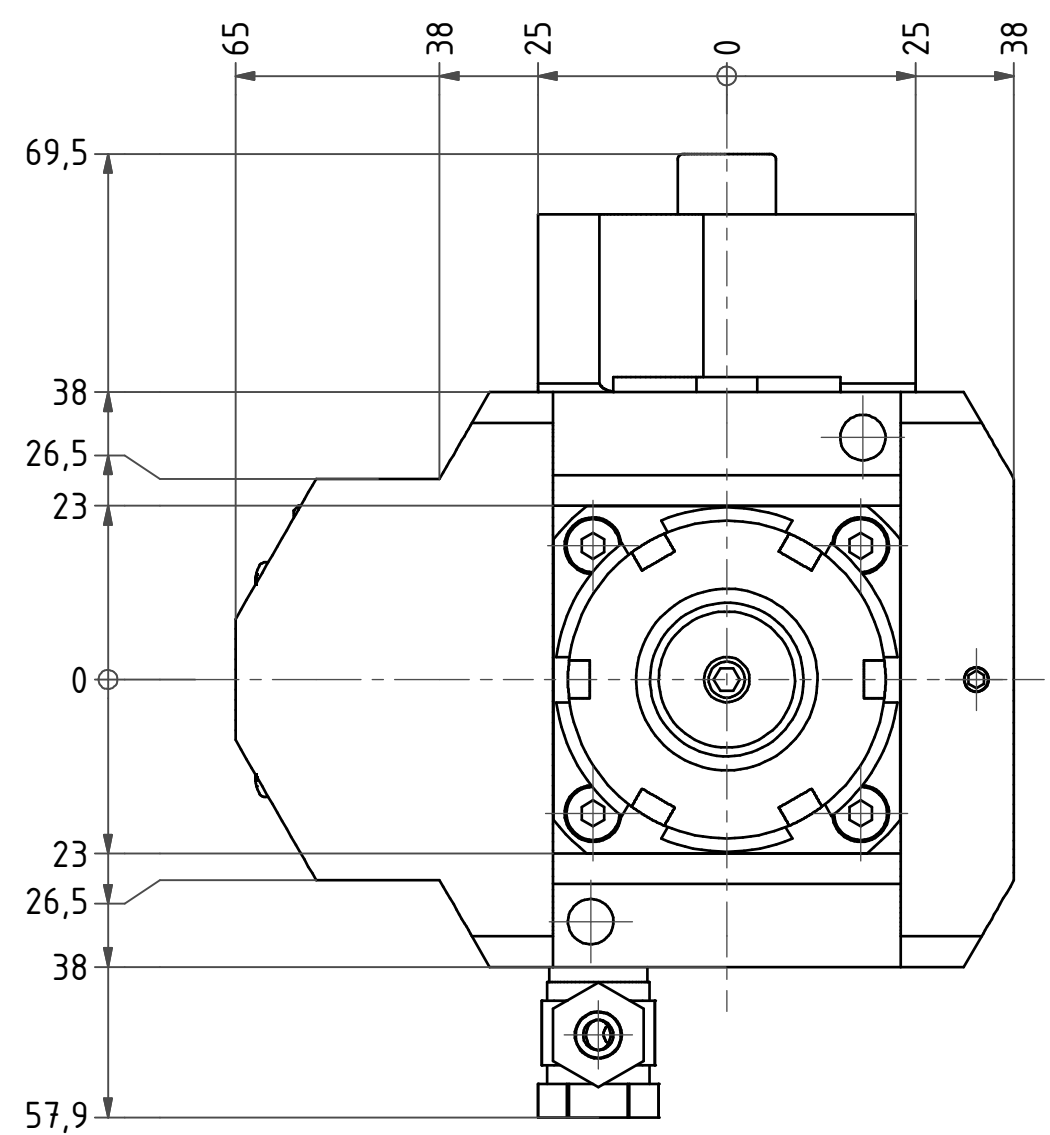
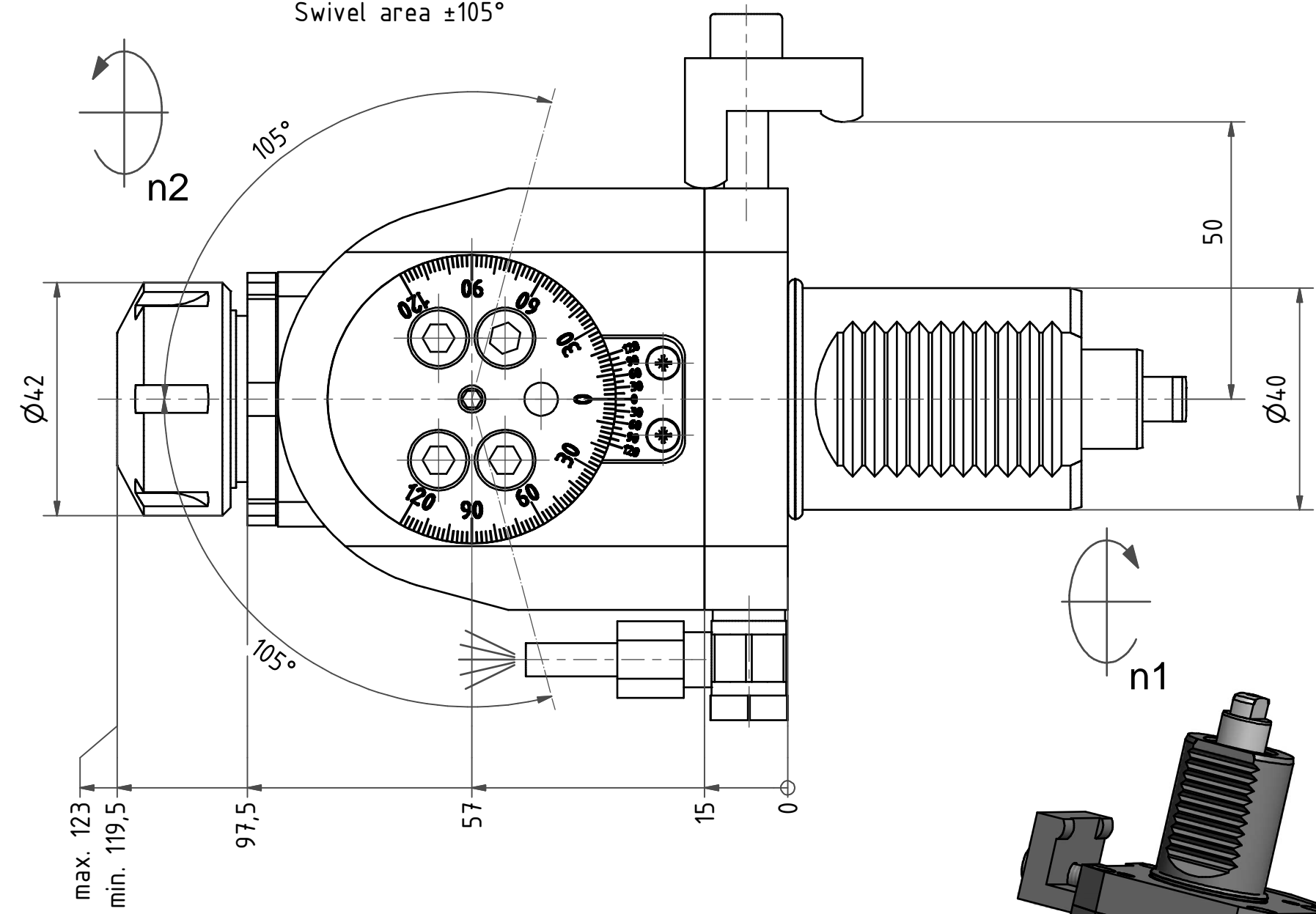

Spannzange / collet ER25 DIN6499
Spannbereich / clamping range: 1,0 - 16,0

Gewindebohrzange / tapping collet
ET-1-25 M3-M10

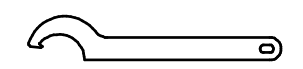
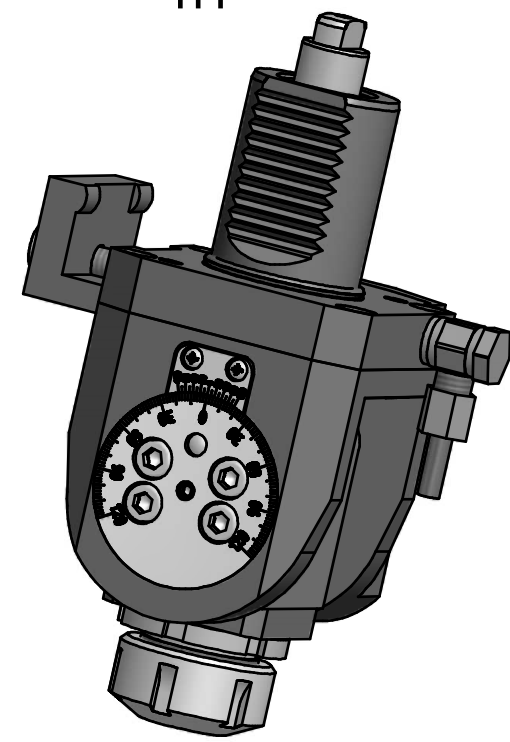

Hakenschlüssel
mit Nase
Hook wrench with
nose end
DIN1810 A 45x50

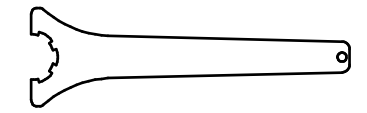

Spannzangenschlüssel
Clamping wrench
225

Copyright **EWS Tool Technologies**
Weitergabe und Vervielfältigung dieser Unterlage,
Verwertung und Mitteilung ihres Inhalts nicht
gestattet, soweit nicht ausdrücklich zugestanden.
Zuwiderhandlungen verpflichten zu Schadenersatz.

Bemerkung - Note	Technische Daten - technical data M1 / M2 = 20 / 20 Nm n1 / n2 = 6000 / 6000 1/min i (N1:N2) = 1:1	Benennung - Title Schwenkkopf <i>Swivel head</i>	name	date	Technische Änderungen vorbehalten! Subject to technical modifications!	
			drawing	Kratschmann		
			Weigle GmbH & Co. KG Maybachstr. 1 D-73066 Uhingen Tel. +49(0)7161/93040-10		Nr. 63.4025TMM250	DIN A3
			File: 63.4025TMM250_OUT.idw		Blatt - page 1 (1)	

6 | 5 | 4 | 3 | 2 | 1