

Spannzange / collet ER32 DIN6499
 Spannbereich / clamping range: 2,0 - 20,0

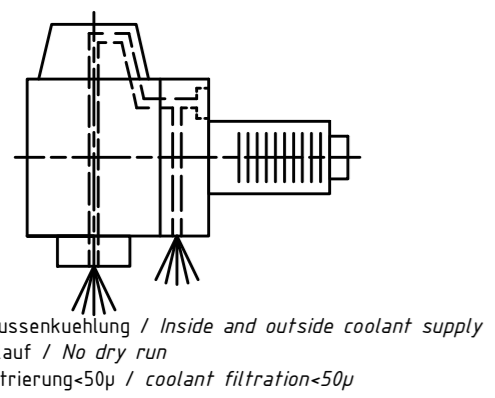
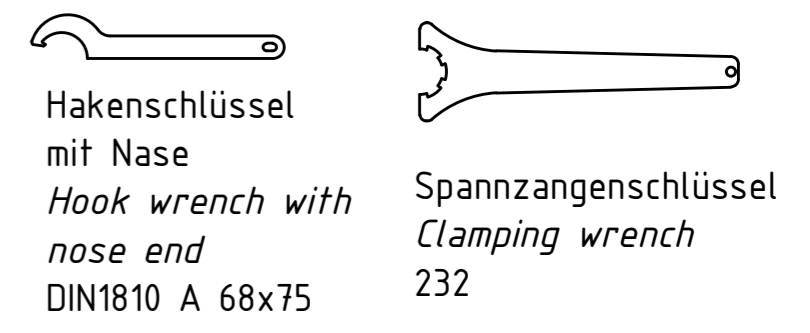
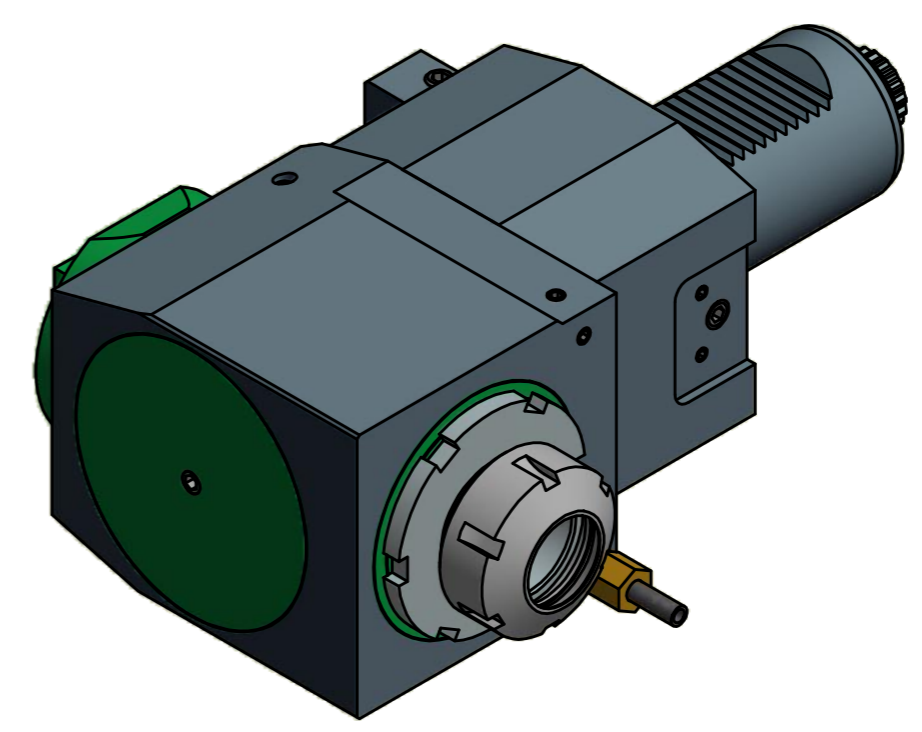
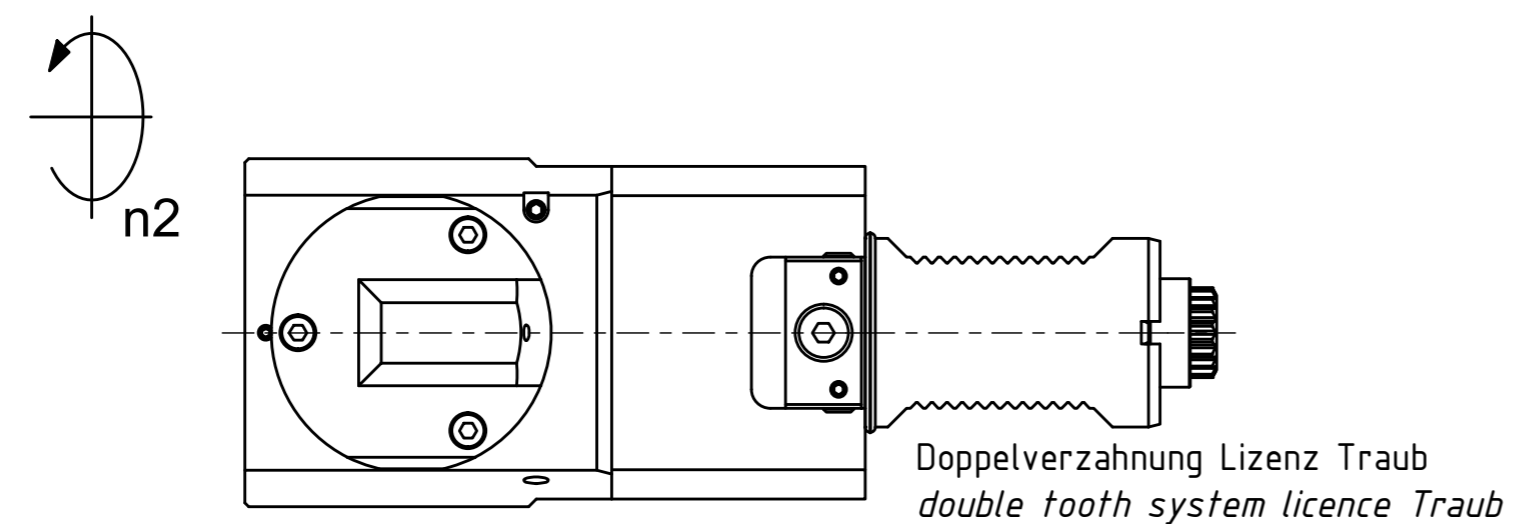
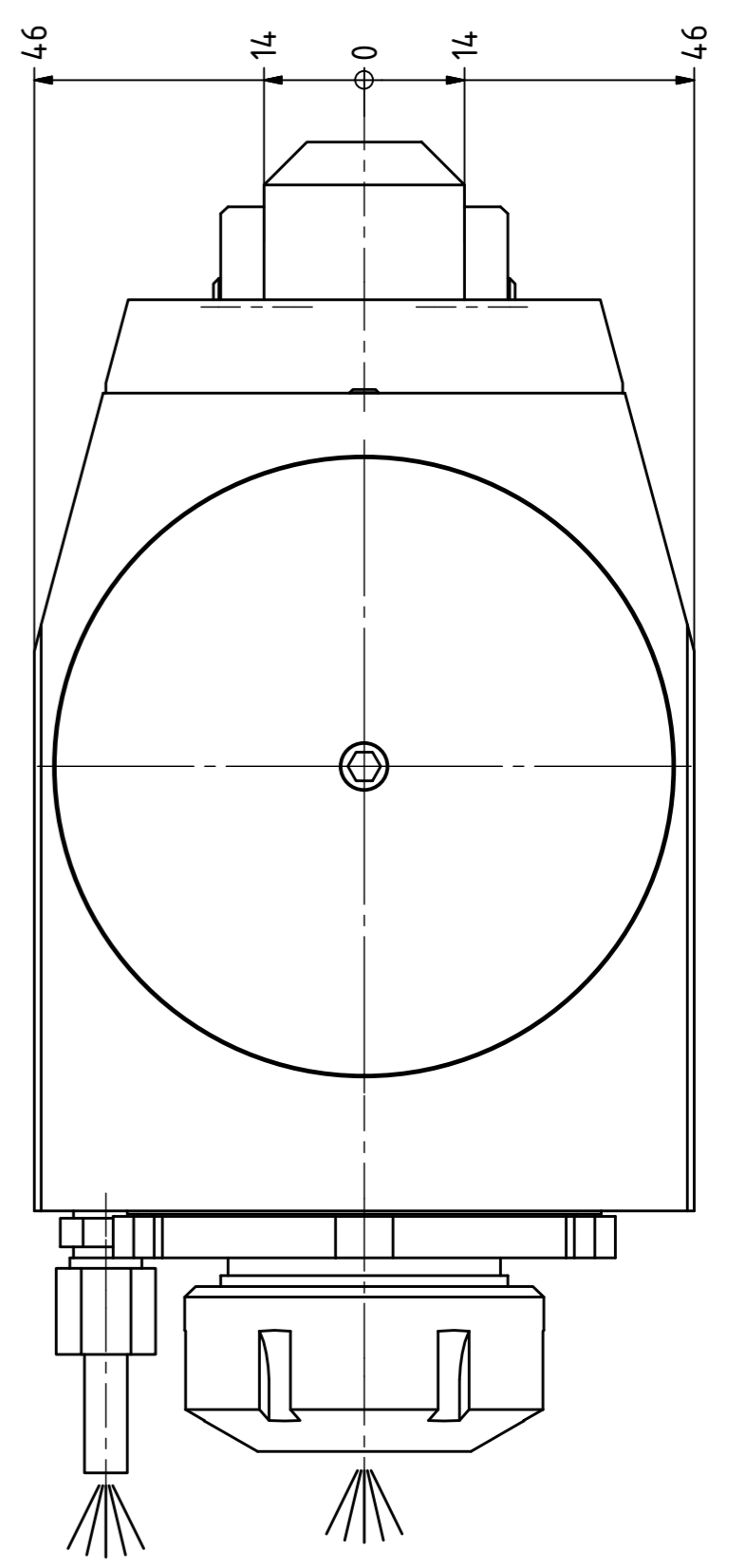
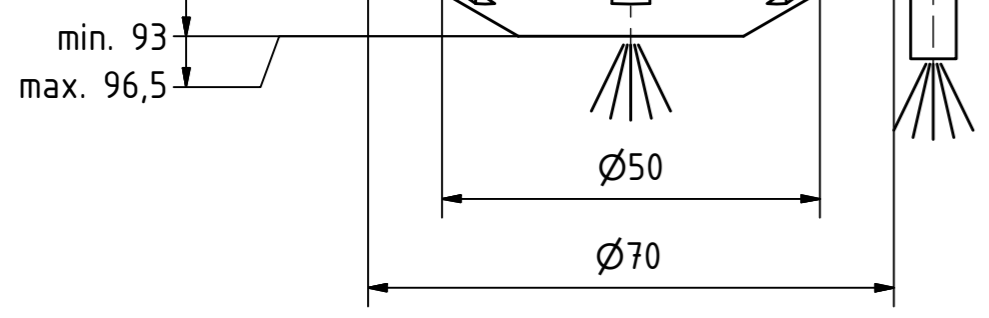

Copyright **EWS Tool Technologies**
 Weitergabe und Vervielfaeltigung dieser Unterlage,
 Verwertung und Mitteilung ihres Inhalts nicht
 gestattet, soweit nicht ausdrecklich zugestanden.
 Zuwiderhandlungen verpflichten zu Schadenersatz.

Bemerkung - Note Nicht ohne Kuehlmittel betreiben! Not for use without coolant-fluid!	Technische Daten - technical data Weight = 11,017 [kg] Torque max. (M1/M2) = 100 / 50 [Nm] Speed max. (n1/n2) = 4000 / 8000 [1/min] Gear ratio (i)=n1:n2 = 1:2 Pressure (pmax) = 70 [bar]	Benennung - Title Radial Bohr und Fräskopf Radial drilling and milling head	<table border="1"> <tr> <td data-bbox="2240 1911 2463 1984"> EWS <small>EWS Weigle GmbH & Co. KG Maybachstr. 1 D-73066 Ulm/ingen www.ews-tool.de</small> </td> <td data-bbox="2463 1911 2700 1984"> Technische Aenderungen vorbehalten! Subject to technical modifications! IDENT: DEWS035841 </td> <td data-bbox="2700 1911 2923 1984"> REV: -/A MNR. </td> </tr> <tr> <td data-bbox="2240 1984 2463 2047"> Nr. - No. 60.50325480RLIK11X120 </td> <td data-bbox="2463 1984 2700 2047"> 151316 </td> <td data-bbox="2700 1984 2923 2047"> QR </td> </tr> </table>	EWS <small>EWS Weigle GmbH & Co. KG Maybachstr. 1 D-73066 Ulm/ingen www.ews-tool.de</small>	Technische Aenderungen vorbehalten! Subject to technical modifications! IDENT: DEWS035841	 REV: -/A MNR.	Nr. - No. 60.50325480RLIK11X120	151316	QR
EWS <small>EWS Weigle GmbH & Co. KG Maybachstr. 1 D-73066 Ulm/ingen www.ews-tool.de</small>	Technische Aenderungen vorbehalten! Subject to technical modifications! IDENT: DEWS035841	 REV: -/A MNR.							
Nr. - No. 60.50325480RLIK11X120	151316	QR							