

Spannzange / collet ER32 DIN6499
 Spannbereich / clamping range: 2,0 - 20,0

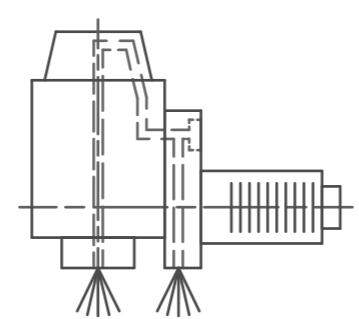

Innen- und Aussenkuehlung / Inside and outside coolant supply
 Kein Trockenlauf / No dry run
 Kuehlmittelfiltrierung<50µ / coolant filtration<50µ

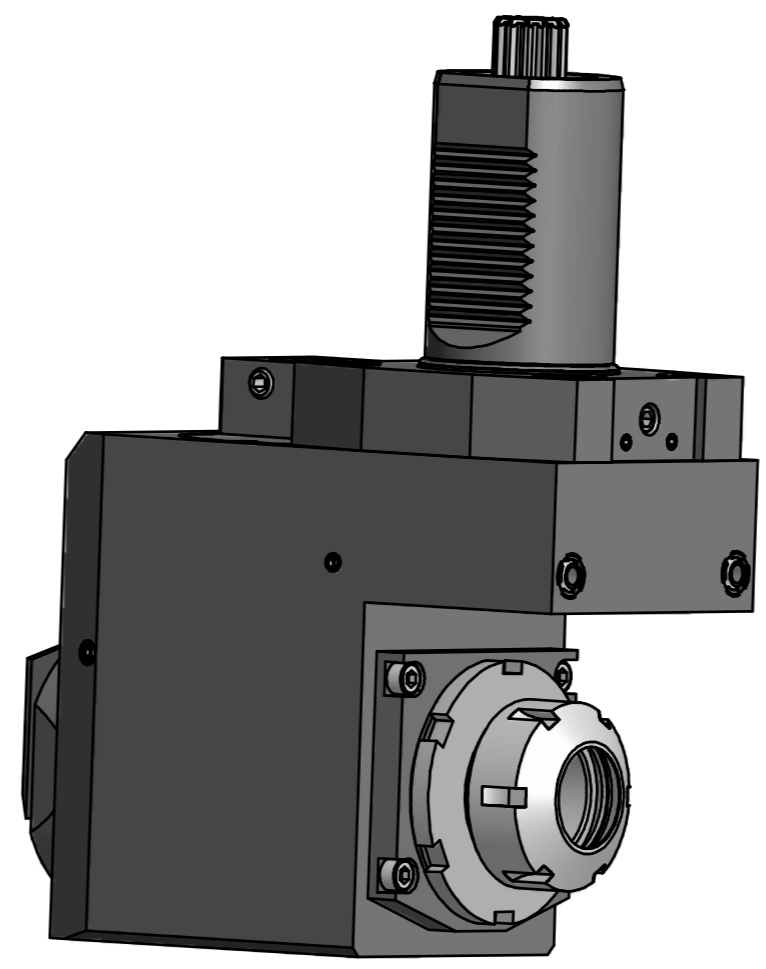
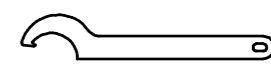

 Hakenschlüssel
 mit Nase
 Hook wrench with
 nose end
 DIN1810 A 68x75

 Spannzangenschlüssel
 Clamping wrench
 232

Copyright **EWS Tool Technologies**
 Weitergabe und Vervielfaeltigung dieser Unterlage,
 Verwertung und Mitteilung ihres Inhalts nicht
 gestattet, soweit nicht ausdruercklich zugestanden.
 Zuwiderhandlungen verpflichten zu Schadenersatz.

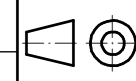
Bemerkung - Note Nicht ohne Kuehlmittel betreiben! Not for use without coolant-Fluid!	Technische Daten - Technical data M1 / M2 = 100 / 50 Nm n1 / n2 = 4000 / 8000 1/min i (N1:N2) = 1:2 Pmax = 70 bar	Benennung - Title Radial Bohr und Fräskopf. zurückges Radial drill. and mill. head offset	name Brosowsky	date 21.11.2006	Technische Aenderungen vorbehalten! Subject to technical modifications! Nr. 80.50325482RIK11 File: 80.50325482IK11_OUT.idw	 DIN A2
			drawing EWS Tool Technologies	Weigle GmbH & Co. KG Maybachstr. 1 D-70668 Uhlringen Tel. +49(0)7161/93040-10		