

Spannzange / collet ER32 DIN6499
Spannbereich / clamping range: 2,0 - 20,0

Gewindebohrzange / tapping collet
ET-1-32 M5-M12

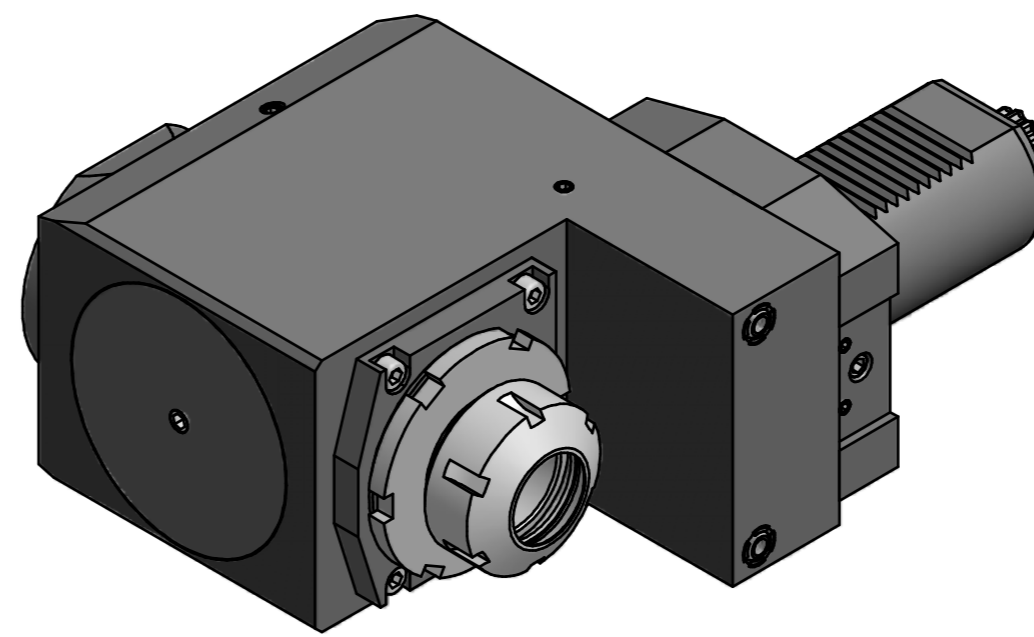
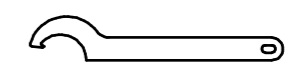

Hakenschlüssel
mit Nase
Hook wrench with
nose end
DIN1810 A 68x75

Spannzangenschlüssel
Clamping wrench
232

Copyright **EWS Tool Technologies**
Weitergabe und Vervielfältigung dieser Unterlage,
Verwertung und Mitteilung ihres Inhalts nicht
gestattet, soweit nicht ausdrücklich zugestanden.
Zuwendungen verpflichten zu Schadenersatz.

Bemerkung - Note	Technische Daten - Technical data		Benennung - Title	name Brosowsky date 21.11.2006 Technische Änderungen vorbehalten! Subject to technical modifications! Nr. 80.50325482R11 MNR: 152611 IDENT: D-EWS-002640 - Blatt - page 1 (1)
	M ₁ / M ₂ = 100 / 50 Nm n ₁ / n ₂ = 4000 / 8000 1/min i (N ₁ :N ₂) = 1:2			
EWS Tool Technologies EWS Werkzeug GmbH & Co. KG Maybachstr. 1 D-73066 Ulm/lingen Tel. +49(0)7161/93040-100			DIN A2	