

Spannzange / collet ER32 DIN6499
 Spannbereich / clamping range: 2,0 - 20,0

Gewindebohrzange / tapping collet
 ET-1-32 M5-M12

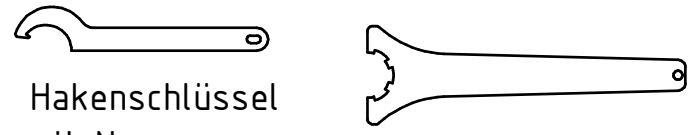
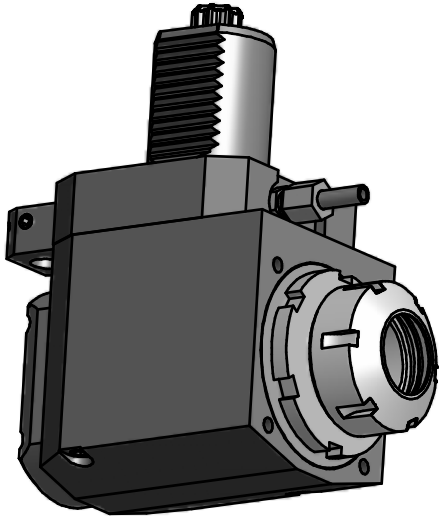

Hakenschlüssel
 mit Nase
 Hook wrench with
 nose end
 DIN1810 A 58x62

Spannzangenschlüssel
 Clamping wrench
 232

Copyright **EWS Tool Technologies**
 Weitergabe und Vervielfaeltigung dieser Unterlage,
 Verwertung und Mitteilung ihres Inhalts nicht
 gestattet, soweit nicht ausdrecklich zugestanden.
 Zuwiderhandlungen verpflichten zu Schadenersatz.

Bemerkung - Note Technische Daten - technical data M1 / M2 = 50 / 25 Nm n1 / n2 = 6000 / 12000 1/min i (N1:N2) = 1:2	Benennung - Title Radial Bohr und Fräskopf <i>Radial drilling and milling head</i>	<table border="1"> <tr> <th>name</th> <th>date</th> </tr> <tr> <td>drawing</td> <td>14.02.2007</td> </tr> </table>	name	date	drawing	14.02.2007	Technische Aenderungen vorbehalten! Subject to technical modifications! Nr. 60.40325482RI1 MNR: 122563 IDENT: D-EWS-002171 - Blatt - page 1 (1)
name	date						
drawing	14.02.2007						