

min. 73  
max. 77,6

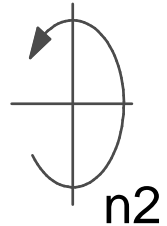

Spannzange / Collet ER16 DIN6499  
Spannbereich / Clamping range: 1,0 - 10,0

Gewindebohrzange / Tapping Collet  
ET-1-16 M1-M6

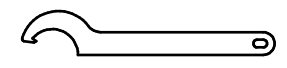
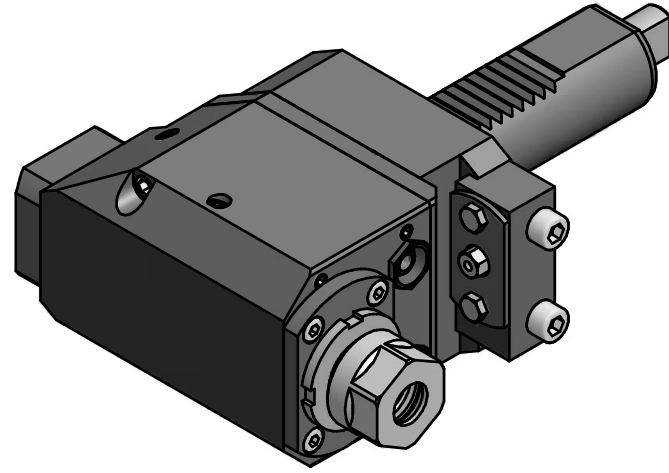

Hakenschlüssel  
mit Nase  
Hook wrench with  
nose end  
DIN1810 A 34x36

Copyright **EWS Tool Technologies**  
Weitergabe und Vervielfaeltigung dieser Unterlage,  
Verwertung und Mitteilung ihres Inhalts nicht  
gestattet, soweit nicht ausdruuecklich zugestanden.  
Zuwiderhandlungen verpflichten zu Schadenersatz.

Bemerkung - Note  	Technische Daten - technical data M1 / M2 = 15 / 5 Nm n1 / n2 = 6000 / 18000 1/min i (N1:N2) = 1:3	Benennung - Title <b>Radial Bohr und Fräskopf</b> <i>Radial drilling and milling head</i>	<table border="1"> <tr> <td>name</td> <td>date</td> </tr> <tr> <td>Schmid</td> <td>08.12.2010</td> </tr> </table> EWS Weigte GmbH & Co. KG Maybachstr. 1 D-73066 Uhingen Tel. +49(0)7161/93040-100	name	date	Schmid	08.12.2010	Technische Aenderungen vorbehalten! Subject to technical modifications! Nr. <b>60.3016ZT1000RI13</b> DIN A3 MNR: 152570 IDENT: D-EWS-097120 B Blatt - page 1 (1)
name	date							
Schmid	08.12.2010							