

Spannzange / collet ER40 DIN6499
Spannbereich / clamping range: 3,0 - 26,0

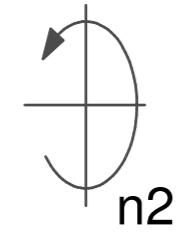

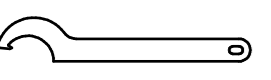
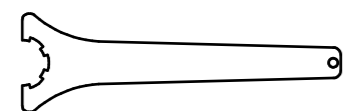
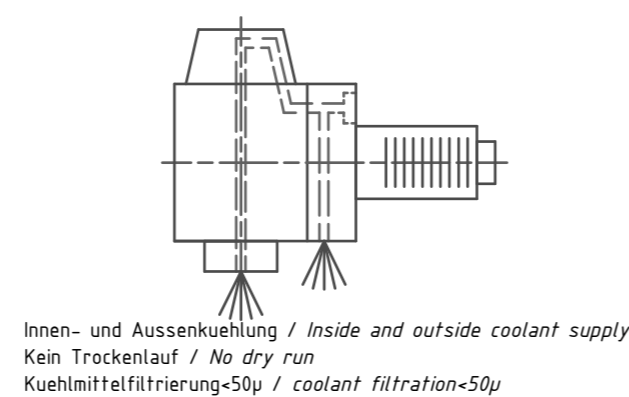

 Hakenschlüssel mit Nase
Hook wrench with nose end
DIN1810 A 80x90

 Spannzangenschlüssel
Clamping wrench
240

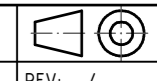

Bemerkung - Note Nicht ohne Kuehlmittel betreiben! Not for use without coolant-fluid! mit Kegelrollenlager with taper roller bearing(s)	Technische Daten - technical data Weight = 14.089 [kg] Torque max. (M1/M2) = 160 / 160 [Nm] Speed max. (n1/n2) = 3000 / 3000 [1/min] Gear ratio (i)=n1:n2 = 1:1 Pressure (pmax) = 70 [bar]
---	---

Benennung - Title
Radial Bohr und Fräskopf
 Radial drilling and milling head

 EWS Weigle GmbH & Co. KG Maybachstr. 1 D-73066 Uhringen www.ews-tools.de	Technische Aenderungen vorbehalten! Subject to technical modifications! IDENT: D-EWS-002742	 MNR REV: -/- 120537
Nr. - No. 60.6040KR5482RIK		 QR

Copyright **EWS Tool Technologies**
 Weitergabe und Vervielfaeltigung dieser Unterlage,
 Verwertung und Mitteilung ihres Inhalts nicht
 gestattet, soweit nicht ausdrucklich zugestanden.
 Zuwiderhandlungen verpflichten zu Schadenersatz.