

Spannzange / collet ER32 DIN6499
 Spannbereich / clamping range: 2,0 - 20,0

Gewindebohrzange / tapping collet
 A ET-1-32 M5-M12

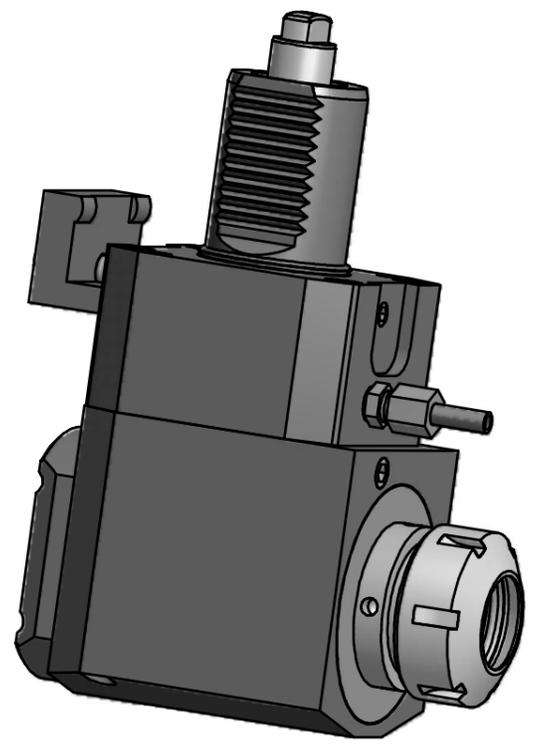
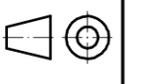

Copyright **EWS Tool Technologies**
 Weitergabe und Vervielfaeltigung dieser Unterlage,
 Verwertung und Mitteilung ihres Inhalts nicht
 gestattet, soweit nicht ausdruuecklich zugestanden.
 Zuwiderhandlungen verpflichten zu Schadenersatz.

| Bemerkung - Note | Technische Daten - technical data M1 / M2 = 50 / 50 Nm n1 / n2 = 6000 / 6000 1/min i (N1:N2) = 1:1 | Benennung - Title Radial Bohr und Fräskopf <i>Radial drilling and milling head</i> | <table border="1"> <tr> <th>name</th> <th>date</th> </tr> <tr> <td>Kratschmann</td> <td>14.03.2007</td> </tr> </table> | name | date | Kratschmann | 14.03.2007 | Technische Aenderungen vorbehalten! Subject to technical modifications! Nr. 60.4032TMM250R File: 60.4032TMM250R_OUT.idw |  DIN A3 Blatt - page 1 (1) |
|--------------------------|---|---|--|------|------|-------------|------------|--|---|
| name | date | | | | | | | | |
| Kratschmann | 14.03.2007 | | | | | | | | |