

Spannzange / collet ER25 DIN6499
Spannbereich / clamping range: 1,0 - 16,0

Gewindebohrzange / tapping collet
ET-1-25 M3-M10

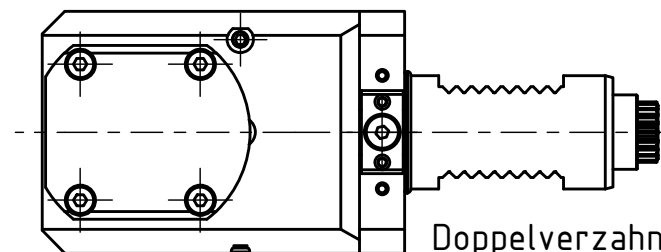
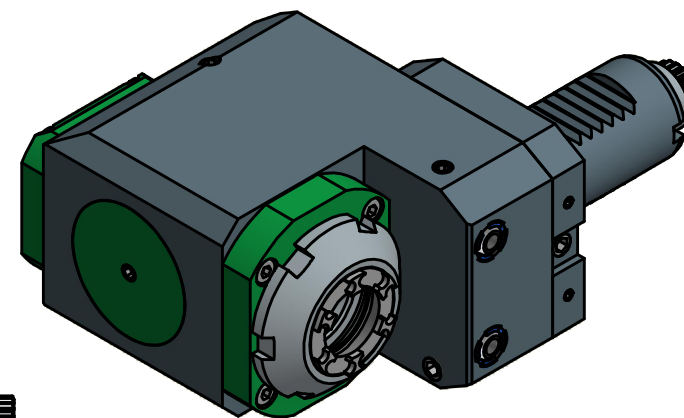
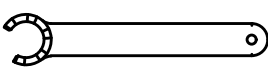

Doppelverzahnung Lizenz Traub
double tooth system licence Traub

Spannzangenschlüssel für
innenliegende Mutter
Clamping wrench for
internal collet
225AX



Hakenschlüssel
mit Nase
Hook wrench with
nose end
DIN1810 A 52x55

Copyright **EWS Tool Technologies**
Weitergabe und Vervielfältigung dieser Unterlage,
Verwertung und Mitteilung ihres Inhalts nicht
gestattet, soweit nicht ausdrücklich zugestanden.
Zuwendungen verpflichten zu Schadenersatz.

Bemerkung - Note

Technische Daten - technical data

Weight = 3.676 [kg]
Torque max. (M1/M2)= 25 / 25 [Nm]
Speed max. (n1/n2) = 8000 / 8000 [1/min]
Gear ratio (i)=n1:n2= 1:1

Benennung - Title

Radial Bohr und Fräskopf, zurückges
Radial drill. and mill. head offset

EWS
Tool Technologies

EWS Weigle GmbH & Co. KG
Maybachstr. 1
D-73066 UHINGEN
www.ews-tools.de

Technische Änderungen vorbehalten!
Subject to technical modifications!

IDENT: D-EWS-085176



REV: -/A

Nr. - No.

80.3025CTXRLIM

MNR.

149267

QR