

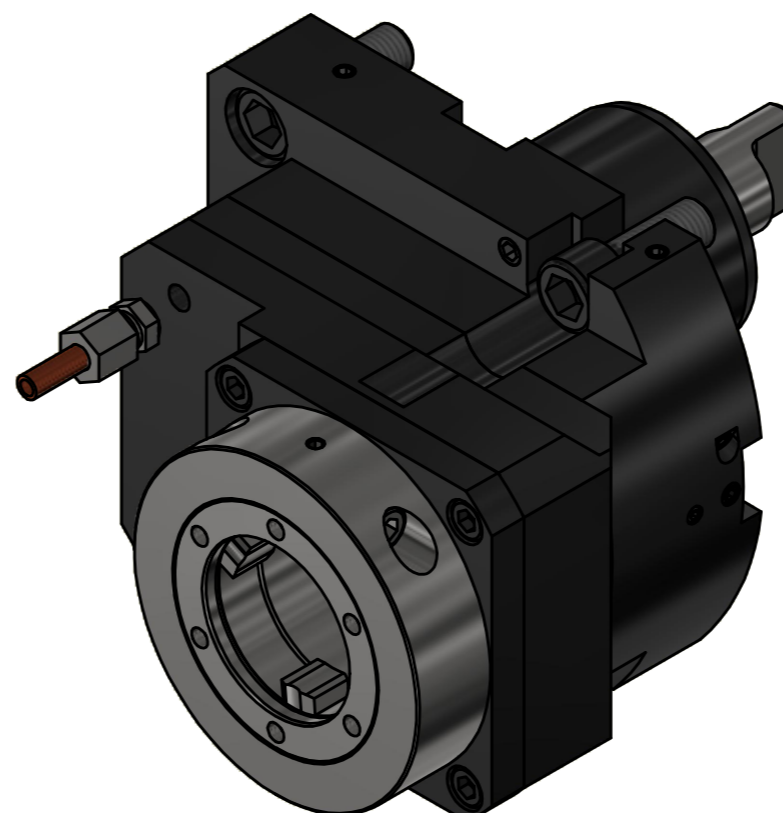

EWS.Varia

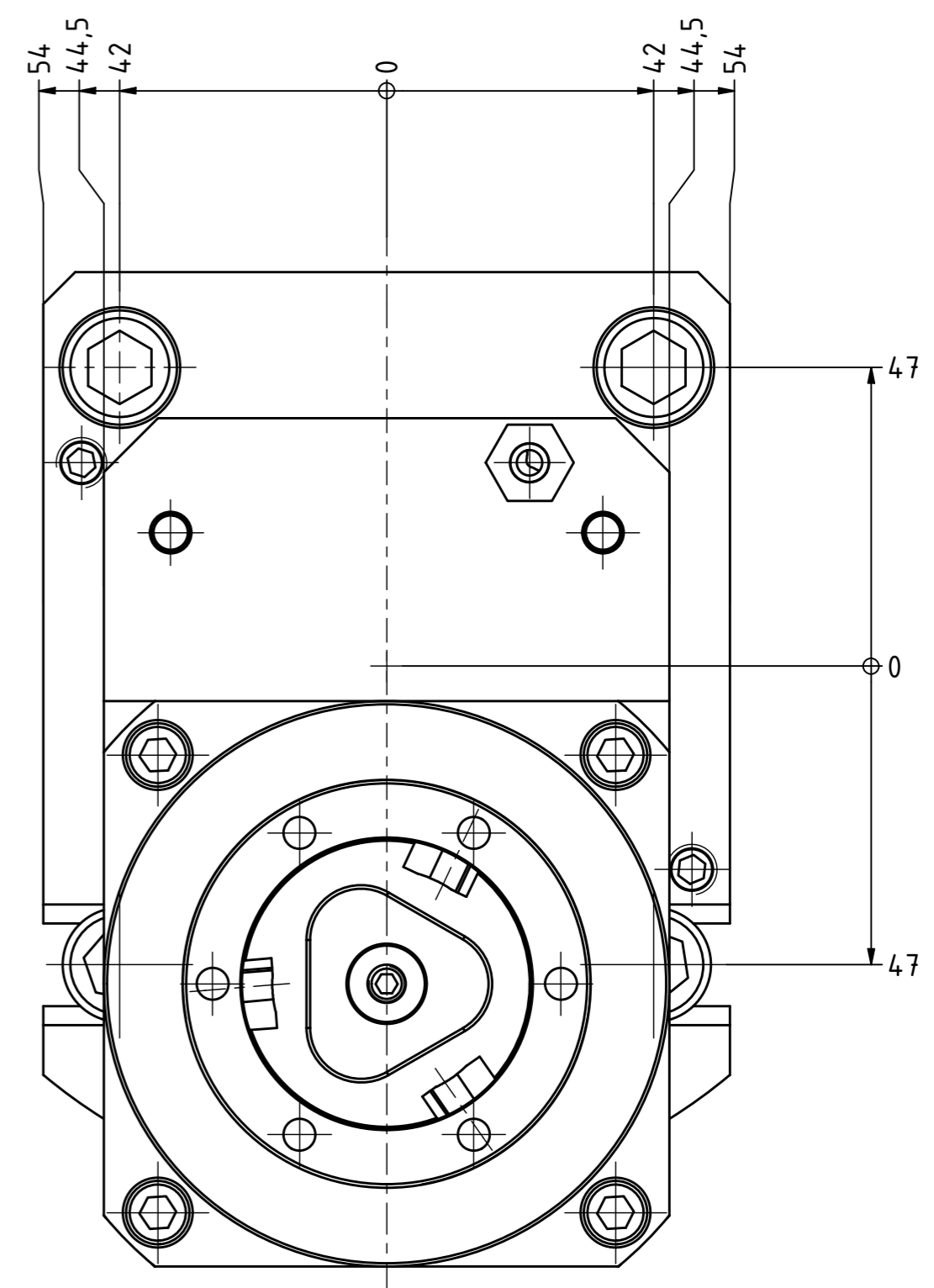

Tech  
Details

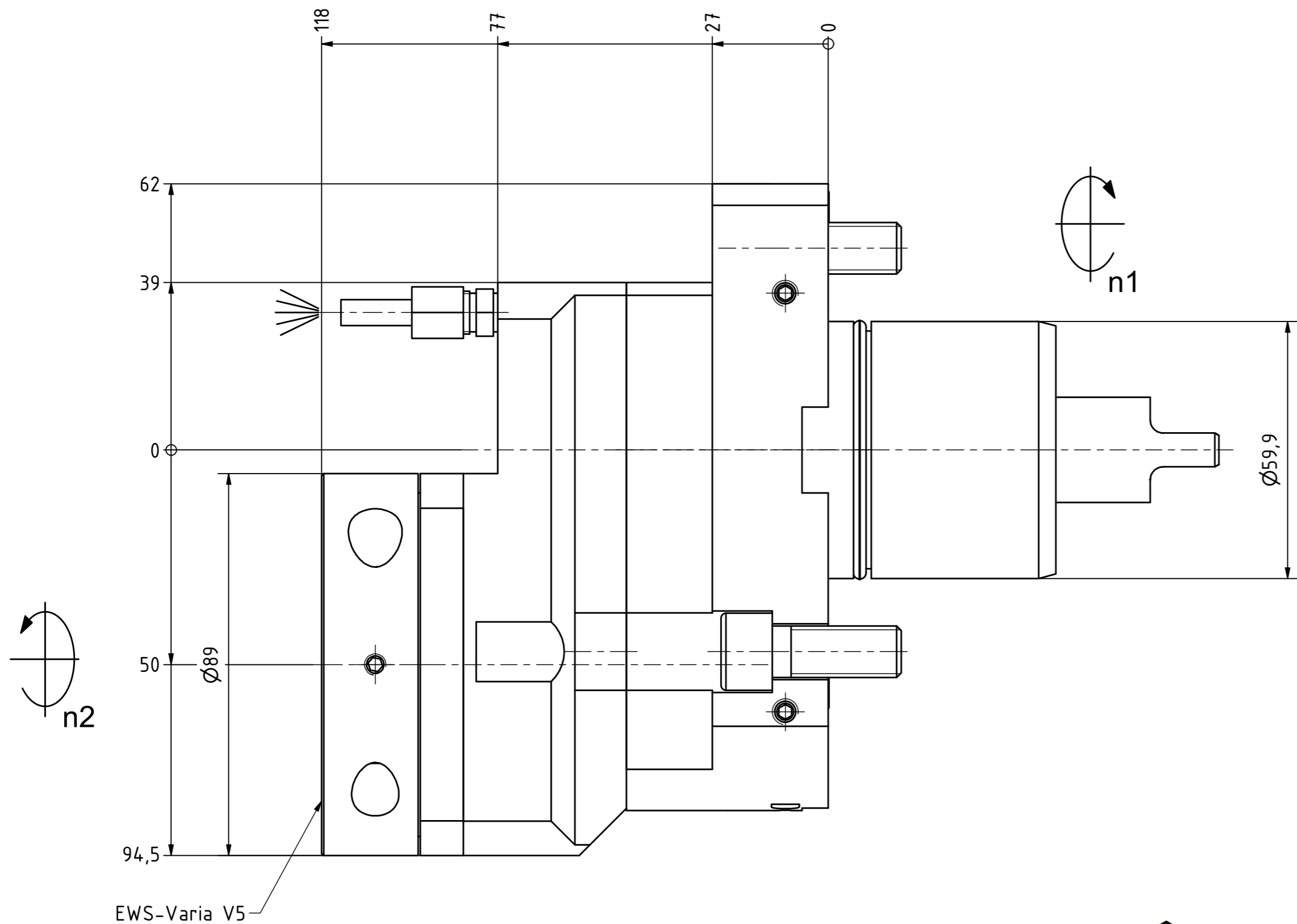

Copyright **EWS Tool Technologies**  
 Weitergabe und Vervielfältigung dieser Unterlage,  
 Verwertung und Mitteilung ihres Inhalts nicht  
 gestattet, soweit nicht ausdrücklich zugestanden.  
 Zuwiderhandlungen verpflichten zu Schadenersatz.

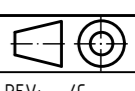
Bemerkung - Note	Technische Daten - technical data <b>Weight</b> = 8.724 [kg] <b>Torque max. (M1/M2)</b> = 50 / 50 [Nm] <b>Speed max. (n1/n2)</b> = 6000 / 6000 [1/min] <b>Gear ratio (i)=n1:n2</b> = 1:1	Benennung - Title <b>Axial Bohr u. Fräskopf achsversetzt</b> <b>Ax. drill. and mill. head offset</b>	 <b>EWS</b> Weigle GmbH & Co. KG Maybachstr. 1 D-73066 Uhlingen www.ews-tools.de	Technische Änderungen vorbehalten! Subject to technical modifications! IDENT: D-EWS-121139 REV: -/C	 <b>QR</b> Nr. - No. <b>50.60V5NL</b> MNR. <b>149231</b>
------------------	--	--	--	--	---