

Capto C3-Aufnahme
Capto C3-Adaptor

Clamping torque : 35Nm

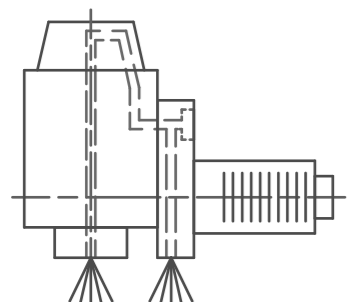

Innen- und Aussenkuehlung / Inside and outside coolant supply
Kein Trockenlauf / No dry run
Kuehmittelfiltrierung <math>< 50\mu</math> / coolant filtration <math>< 50\mu</math>

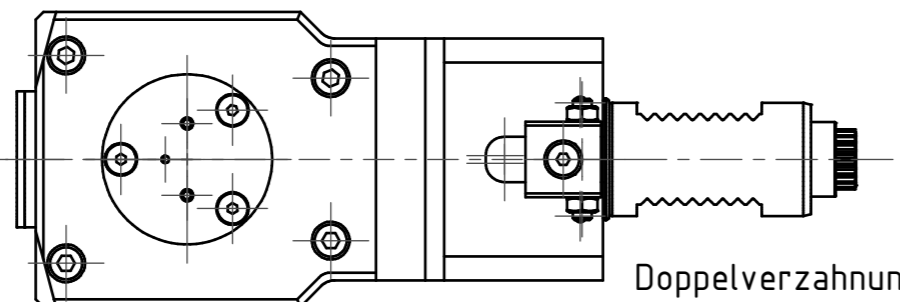

Doppelverzahnung Lizenz Traub
double tooth system licence Traub

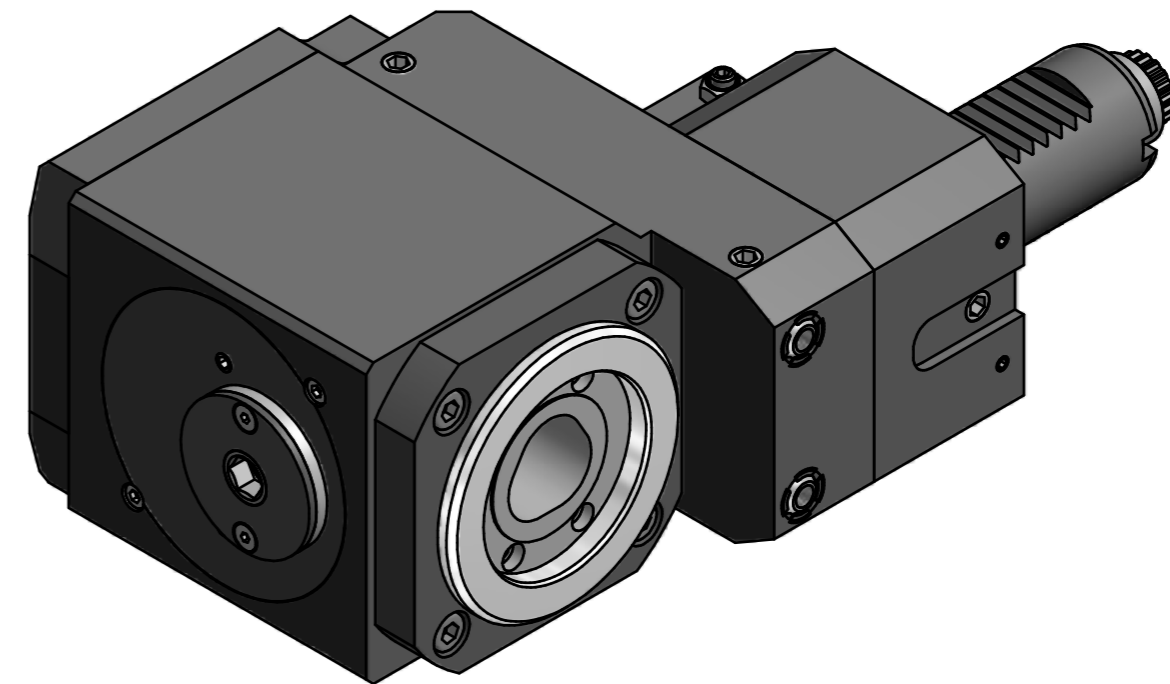

Bemerkung - Note Nicht ohne Kuehmittel betreiben! Not for use without coolant-fluid!	Technische Daten - Technical data $M_1 / M_2 = 25 / 25 \text{ Nm}$ $n_1 / n_2 = 8000 / 8000 \text{ 1/min}$ $i (N_1:N_2) = 1:1$ $p_{max} = 70 \text{ bar}$	Benennung - Title Radial Bohr und Fräskopf, zurückges Radial drill. and mill. head offset	name Theiss	date 21.05.2012	Technische Aenderungen vorbehalten! Subject to technical modifications! Nr. 80.30C3LCTXRLIK MNR: 121460 IDENT: D-EWS-120962 A Blatt - page 1 (1)

Copyright **EWS Tool Technologies**
Weitergabe und Vervielfaeltigung dieser Unterlage,
Verwertung und Mitteilung ihres Inhalts nicht
gestattet, soweit nicht ausdruercklich zugestanden.
Zuwaerhandlungen verpflichtet zu Schadenersatz.

