

Spannzange / collet ER20 DIN6499
 Spannereich / clamping range: 1,0 - 13,0

Gewindebohrzange / tapping collet
 ET-1-20 M2-M6

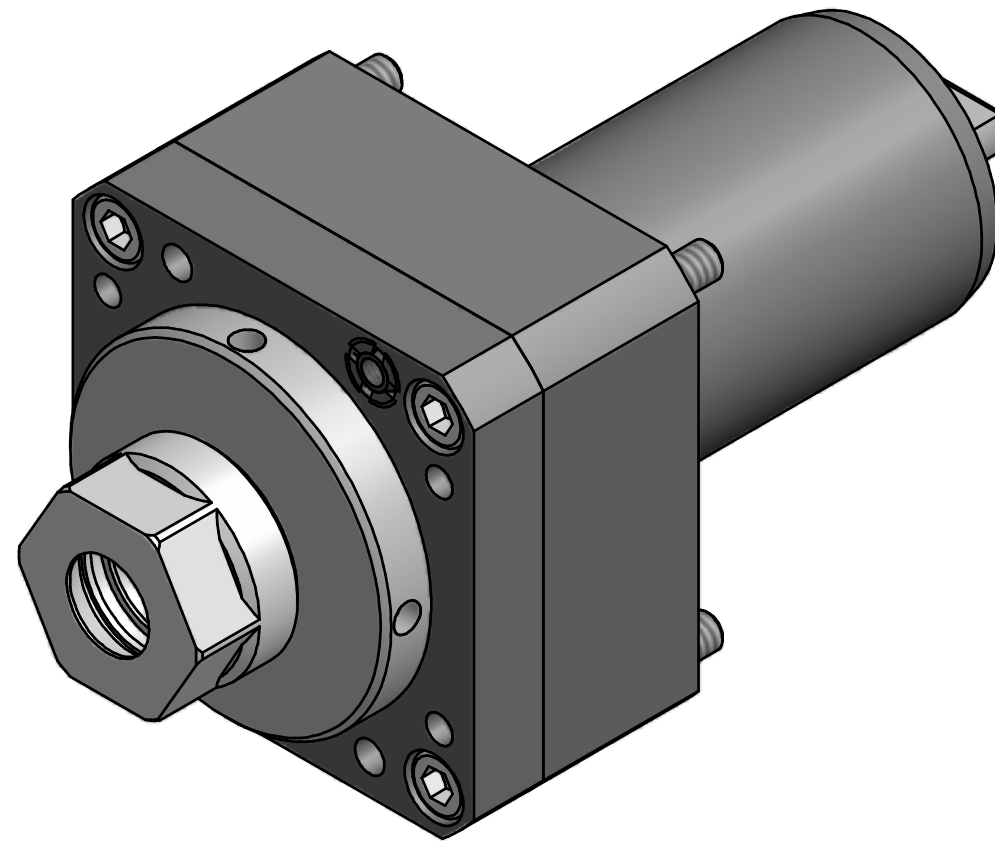

 Hakenschlüssel
 mit Zapfen
 Hook wrench
 with fixed pin
 DIN1810 B 58x62

Copyright **EWS Tool Technologies**
 Weitergabe und Vervielfältigung dieser Unterlage,
 Verwertung und Mitteilung ihres Inhalts nicht
 gestattet, soweit nicht ausdrücklich zugestanden.
 Zuwiderhandlungen verpflichten zu Schadenersatz.

Bemerkung - Note	Technische Daten - technical data $M_1 / M_2 = 20 / 20 \text{ Nm}$ $n_1 / n_2 = 6000 / 6000 \text{ 1/min}$ $i (N_1:N_2) = 1:1$	Benennung - Title Axial Bohr und Fräskopf <i>Axial drilling and milling head</i>	name	date	Technische Änderungen vorbehalten! <i>Subject to technical modifications!</i>	 Nr. 40.4520CL2000 DIN A3
			drawing	Sigel		
			 EWS Weigelt GmbH & Co. KG Maybachstr. 1 D-73066 Uhingen Tel. +49(0)7161/93040-100		MNR: 149113 IDENT: D-EWS-133232 - Blatt - page 1 (1)	