

Hydrodehnfutter / hydraulic chuck NBC-20/25-46

Hülsen / collets 28.20xxHYDSP

XX (Ø) 3 4 5 6 7 8 9 10 12 14 16
 1/8 3/16 1/4 5/16 3/8 7/16 1/2 9/16 5/8

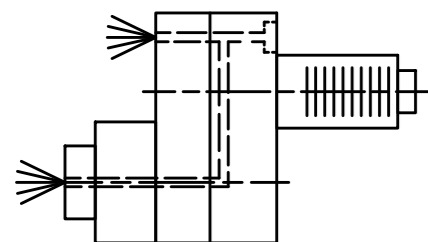
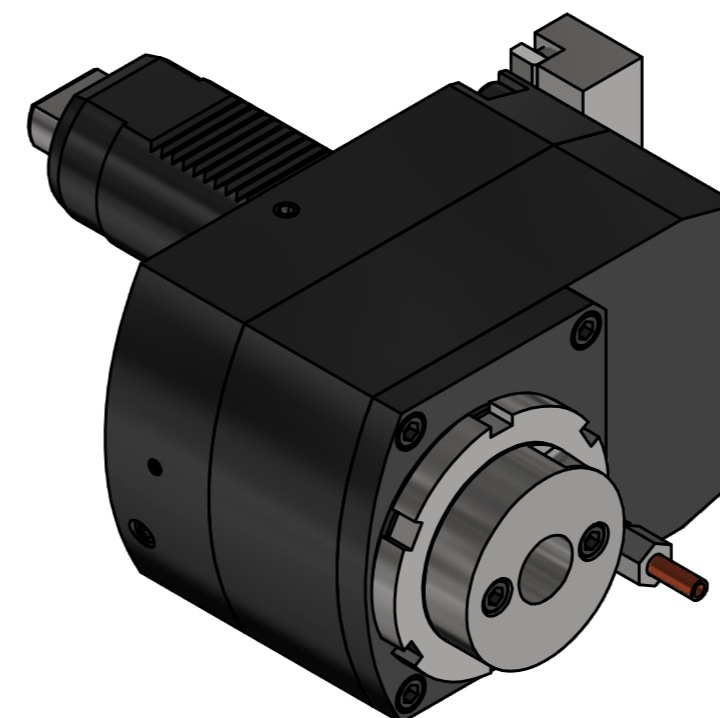

Innen- und Aussenkuehlung / Inside and outside coolant supply
 Kein Trockenlauf / No dry run
 Kuehlmittelfiltrierung=50µ / coolant filtration=50µ

Copyright **EWS Tool Technologies**
 Weitergabe und Vervielfaeltigung dieser Unterlage,
 Verwertung und Mitteilung ihres Inhalts nicht
 gestattet, soweit nicht ausdrecklich zugestanden.
 Zuwiderhandlungen verpflichten zu Schadenersatz.

<p>Bemerkung - Note Nicht ohne Kuehlmittel betreiben! Not for use without coolant-fluid!</p>	<p>Technische Daten - technical data Weight = 11,843 [kg] Torque max. (M1/M2) = 90 / 30 [Nm] Speed max. (n1/n2) = 4200 / 12600 [1/min] Gear ratio (i)=n1:n2 = 1:3 Pressure (pmax) = 70 [bar]</p>	<p>Benennung - Title Axial Bohr u. Fräskopf achsversetzt Ax. drill. and mill. head offset</p>	<p>EWS Tool Technologies <small>EWS Weigle GmbH & Co. KG Maybachstr. 1 D-73066 Uhlingen www.ews-tools.de</small></p>	<p>Technische Aenderungen vorbehalten! Subject to technical modifications! IDENT: DEWS147457 REV: -/A</p>	<p>Nr. - No. 50.5020HYDVL5LIK13 MNR. 121427</p>	<p>QR</p>
--	---	---	---	--	--	------------------