

Spannzange / collet ER32 DIN6499
 Spannbereich / clamping range: 2,0 - 20,0

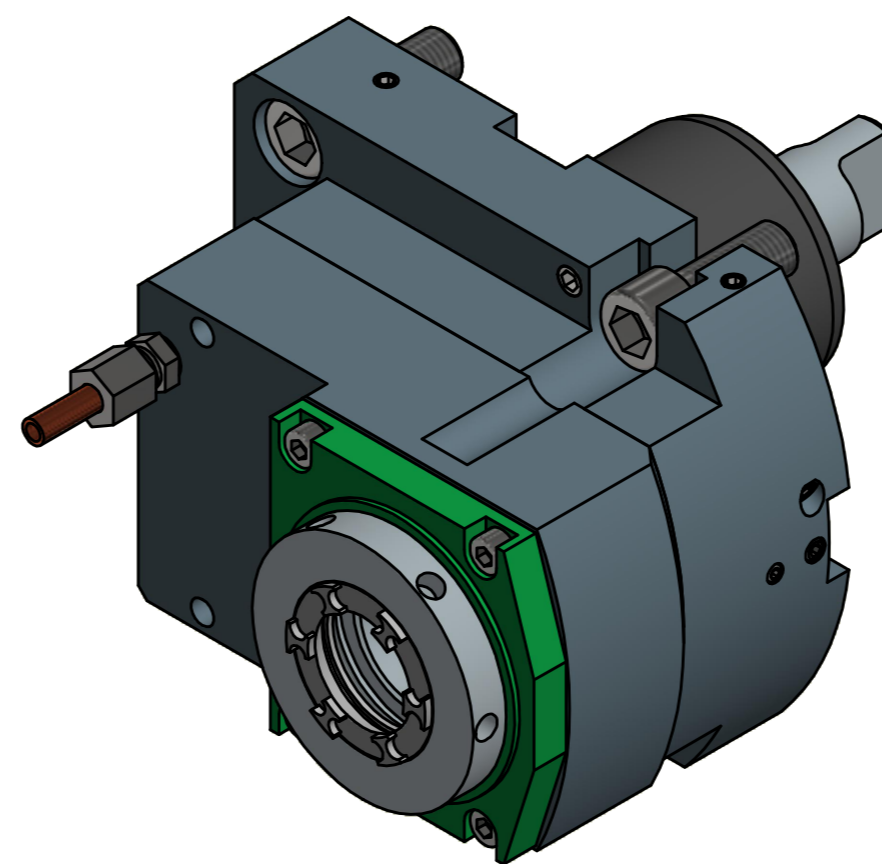

Gewindebohrzange / tapping collet
 ET-1-32 M5-M12



Hakenschlüssel mit Zapfen
 Hook wrench with fixed pin
 DIN1810 B 58x62

Spannzangenschlüssel innenliegende Mutter
 Clamping wrench for internal collet
 232AX

Copyright **EWS Tool Technologies**
 Weitergabe und Vervielfältigung dieser Unterlage, Verwertung und Mitteilung ihres Inhalts nicht gestattet, soweit nicht ausdrücklich zugestanden. Zuwiderhandlungen verpflichten zu Schadenersatz.

Bemerkung - Note	Technische Daten - technical data Weight = 7.681 [kg] Torque max. (M1/M2) = 50 / 25 [Nm] Speed max. (n1/n2) = 6000 / 12000 [1/min] Gear ratio (i)=n1:n2 = 1:2	Benennung - Title Axial Bohr u. Fräskopf achsversetzt Ax. drill. and mill. head offset	 EWS Weigle GmbH & Co. KG Maybachstr. 1 D-73066 Uhingen www.ews-tools.de	Technische Änderungen vorbehalten! Subject to technical modifications! IDENT: D-EWS-154134 REV: -/D MNR.	
			Nr. - No. 50.6032NL11M	148675	