

Spannzange / collet ER20 DIN6499
 Spannbereich / clamping range: 1,0 - 13,0

Gewindebohrzange / tapping collet
 ET-1-20 M2-M6

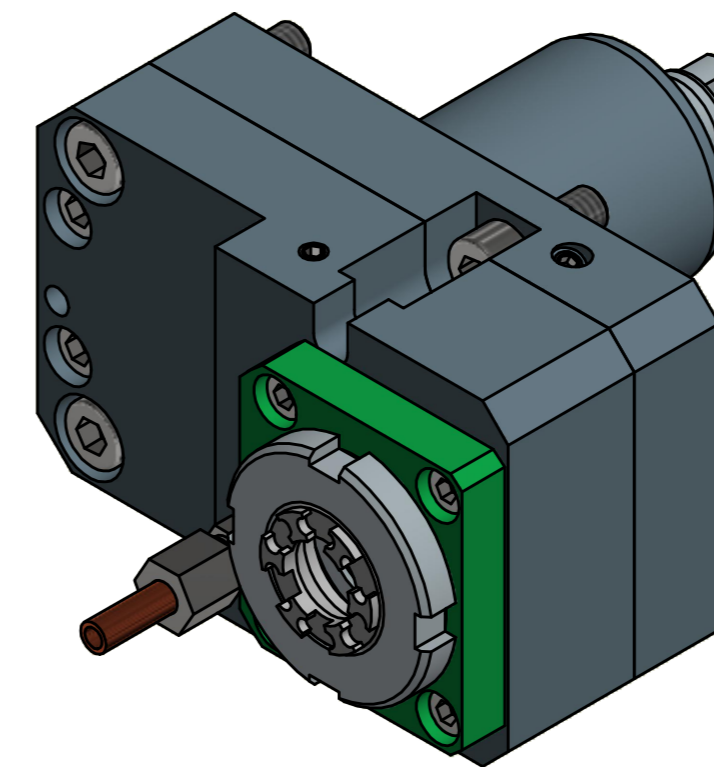
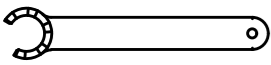
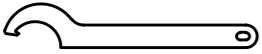

 Spannzangenschlüssel für
 innenliegende Mutter
 Clamping wrench for
 internal collet
 220AX

 Hakenschlüssel
 mit Nase
 Hook wrench with
 nose end
 DIN1810 A 45x50

Copyright **EWS Tool Technologies**
 Weitergabe und Vervielfältigung dieser Unterlage,
 Verwertung und Mitteilung ihres Inhalts nicht
 gestattet, soweit nicht ausdrücklich zugestanden.
 Zuwiderhandlungen verpflichten zu Schadenersatz.

Bemerkung - Note	Technische Daten - technical data Weight = 3.577 [kg] Torque max. (M1/M2) = 32 / 16 [Nm] Speed max. (n1/n2) = 6000 / 12000 [1/min] Gear ratio (i)=n1:n2 = 1:2	Benennung - Title Axial Bohr u. Fräskopf achsversetzt Ax. drill. and mill. head offset	EWS EWS Weigle GmbH & Co. KG Maybachstr. 1 D-73066 Uhingen www.ews-tool.de	Technische Änderungen vorbehalten! Subject to technical modifications! IDENT: DEWS029871 REV: -/A MNR. 149374	
------------------	---	--	--	--	---

Nr. - No.
50.4520BND180911MX50