

max. Fraeserdurchmesser $\varnothing 80$
 max. saw milling diameter

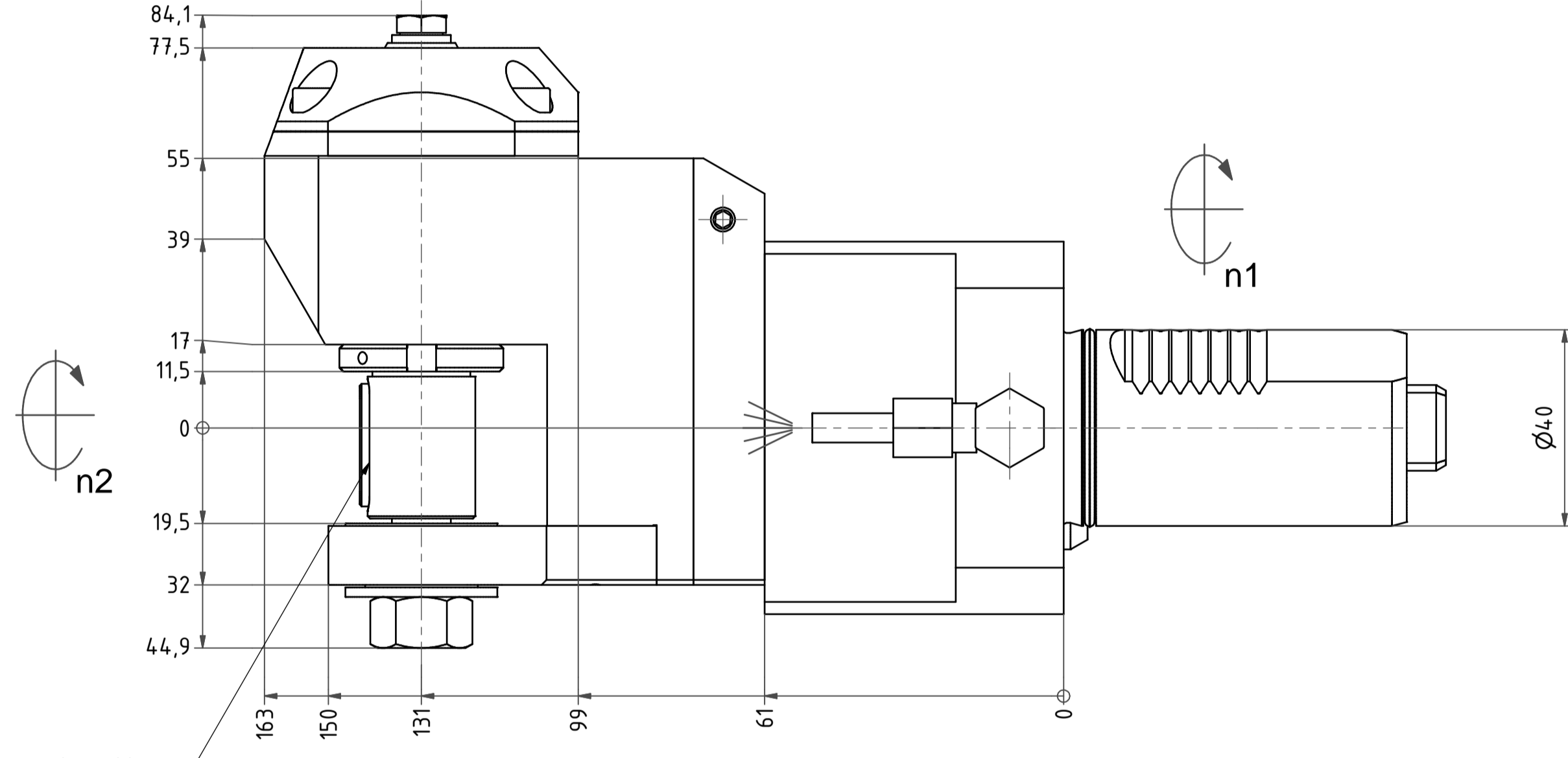

Fraeserwelle austauschbar
 spindle removable

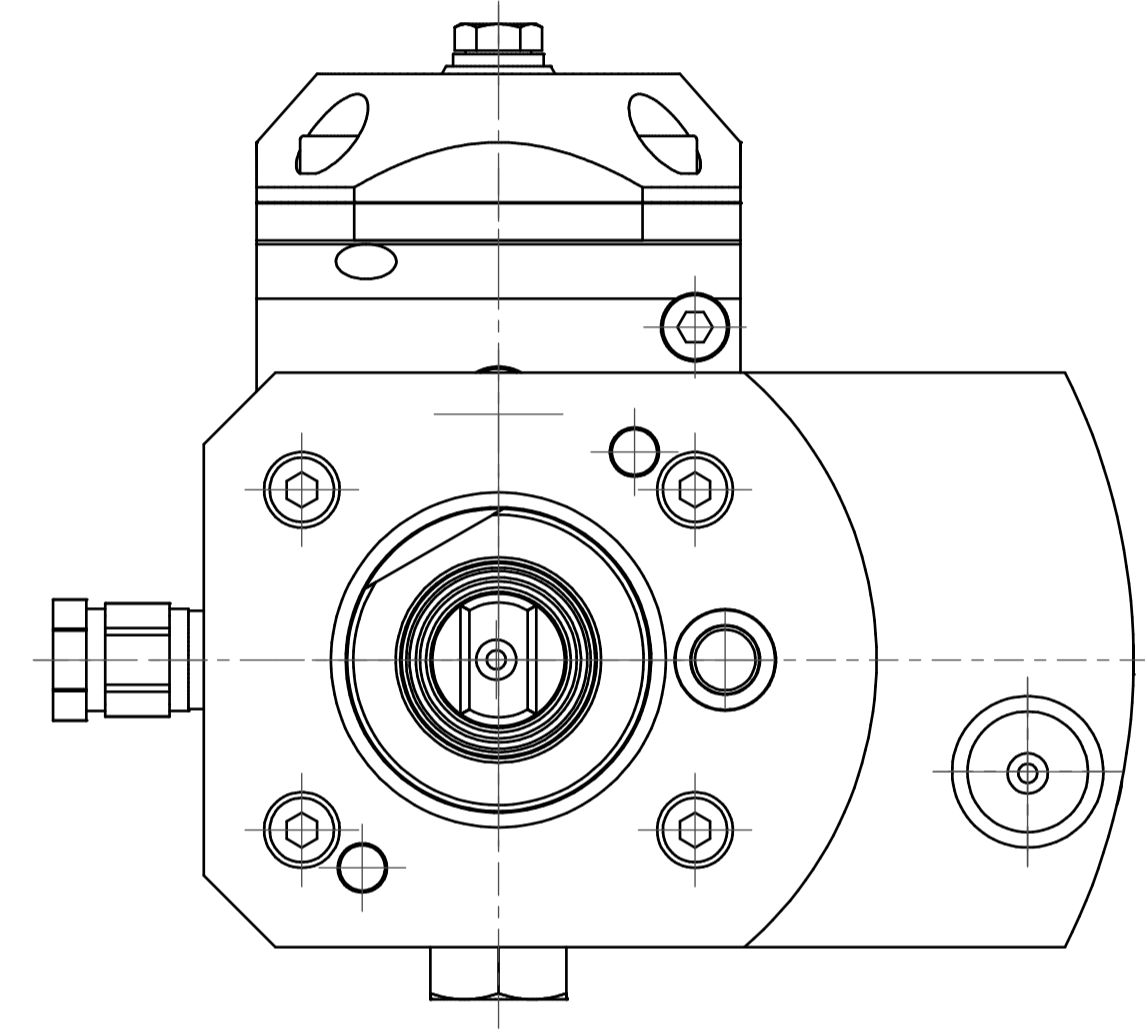
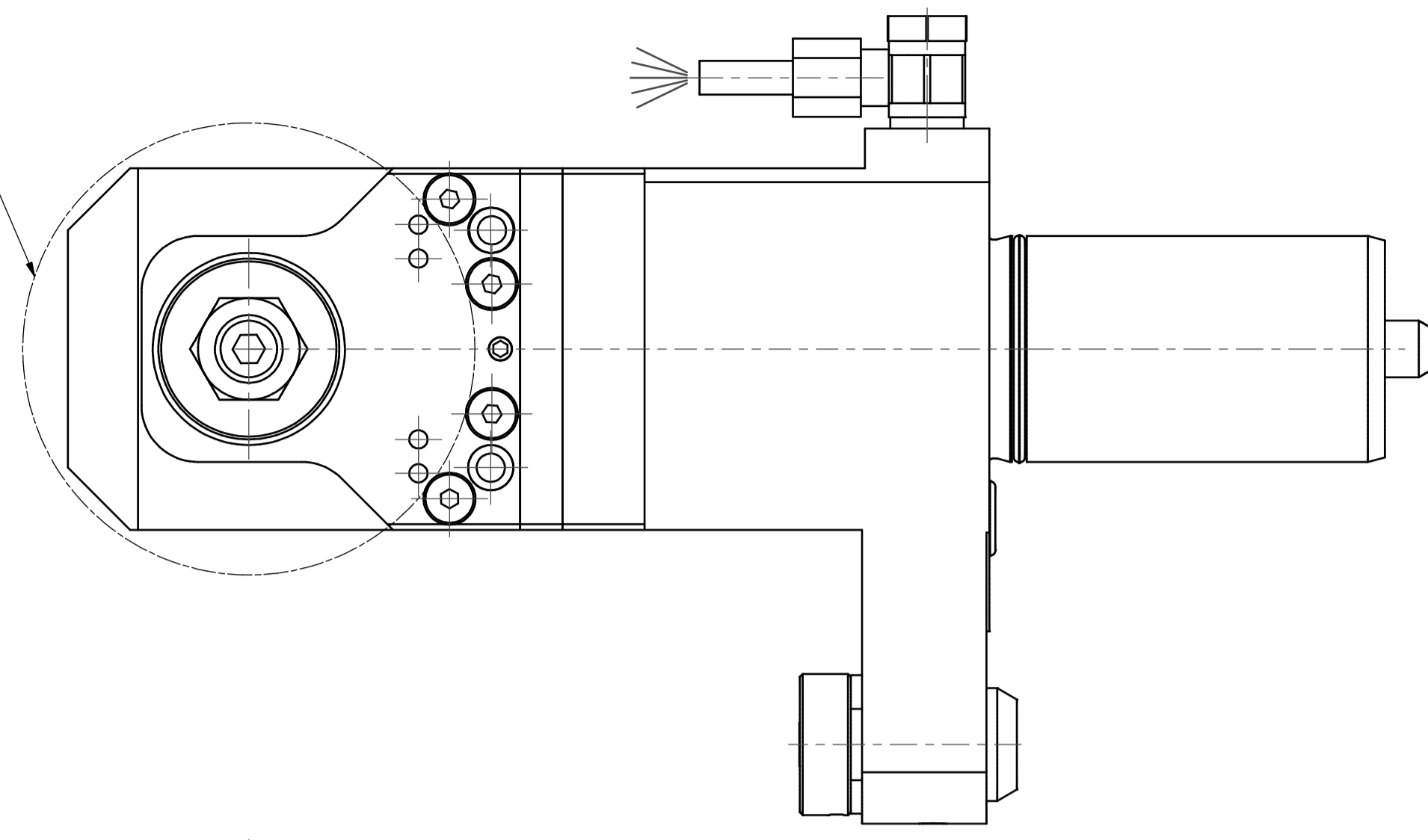
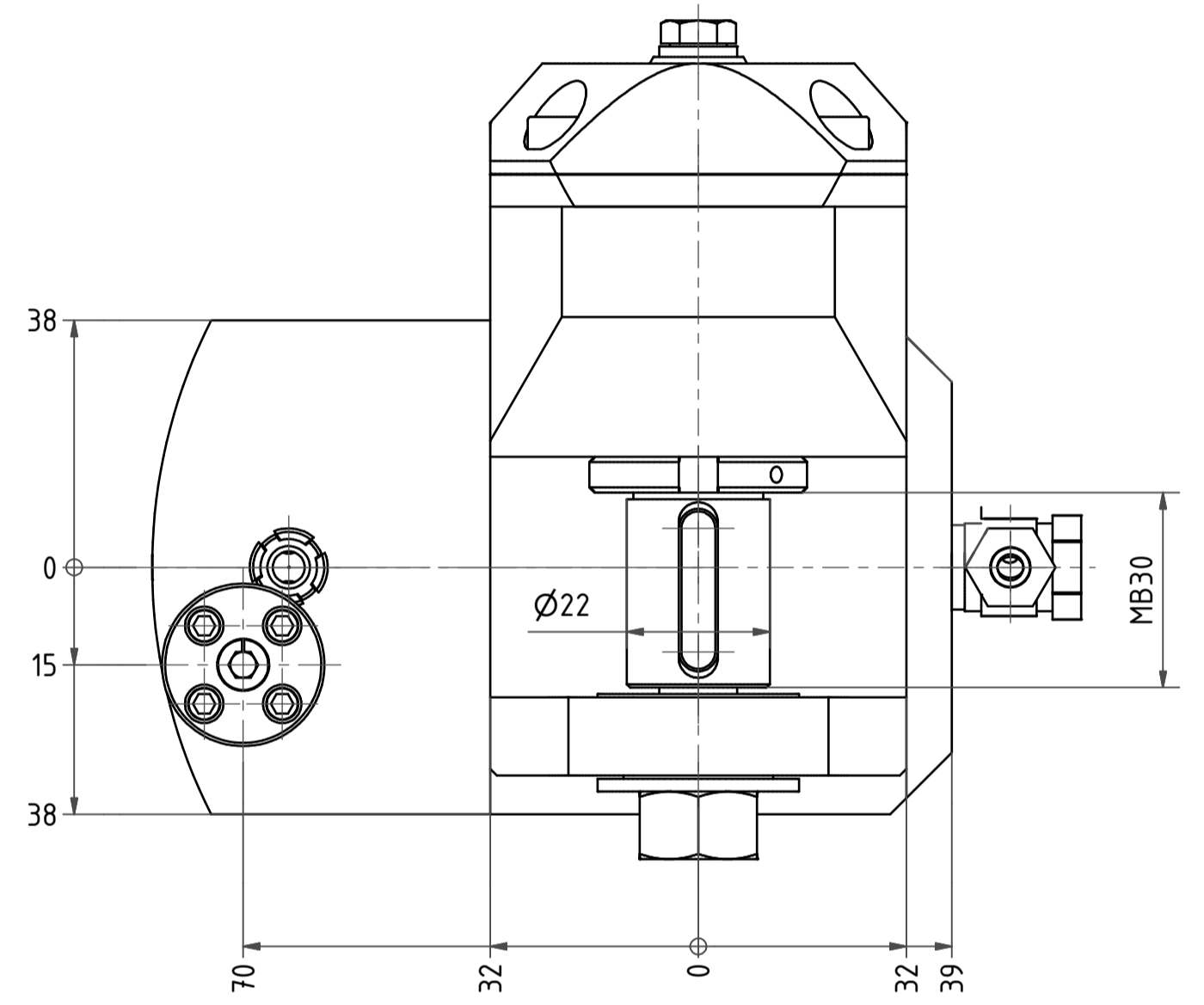

Ausrichtbolzen ist über ein Exzenter einstellbar.
 The bolt is adjustable via eccentric.

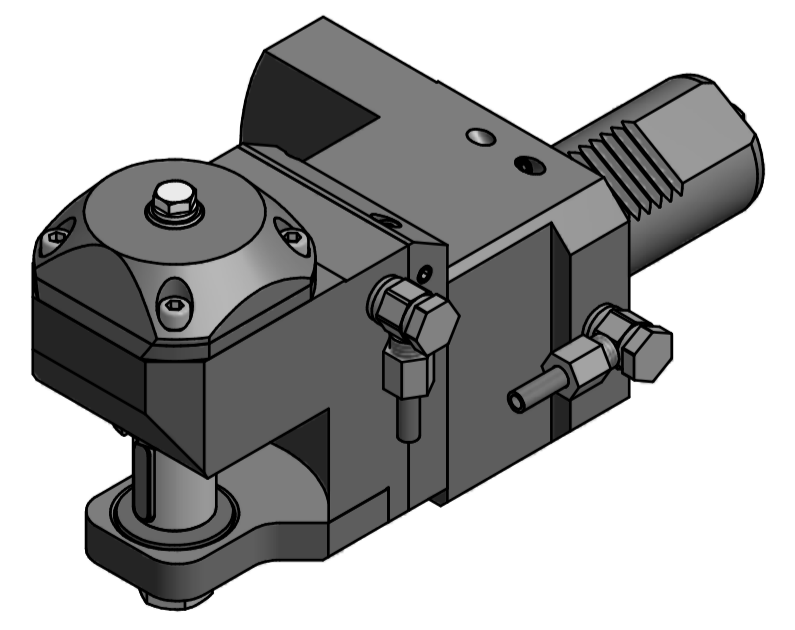
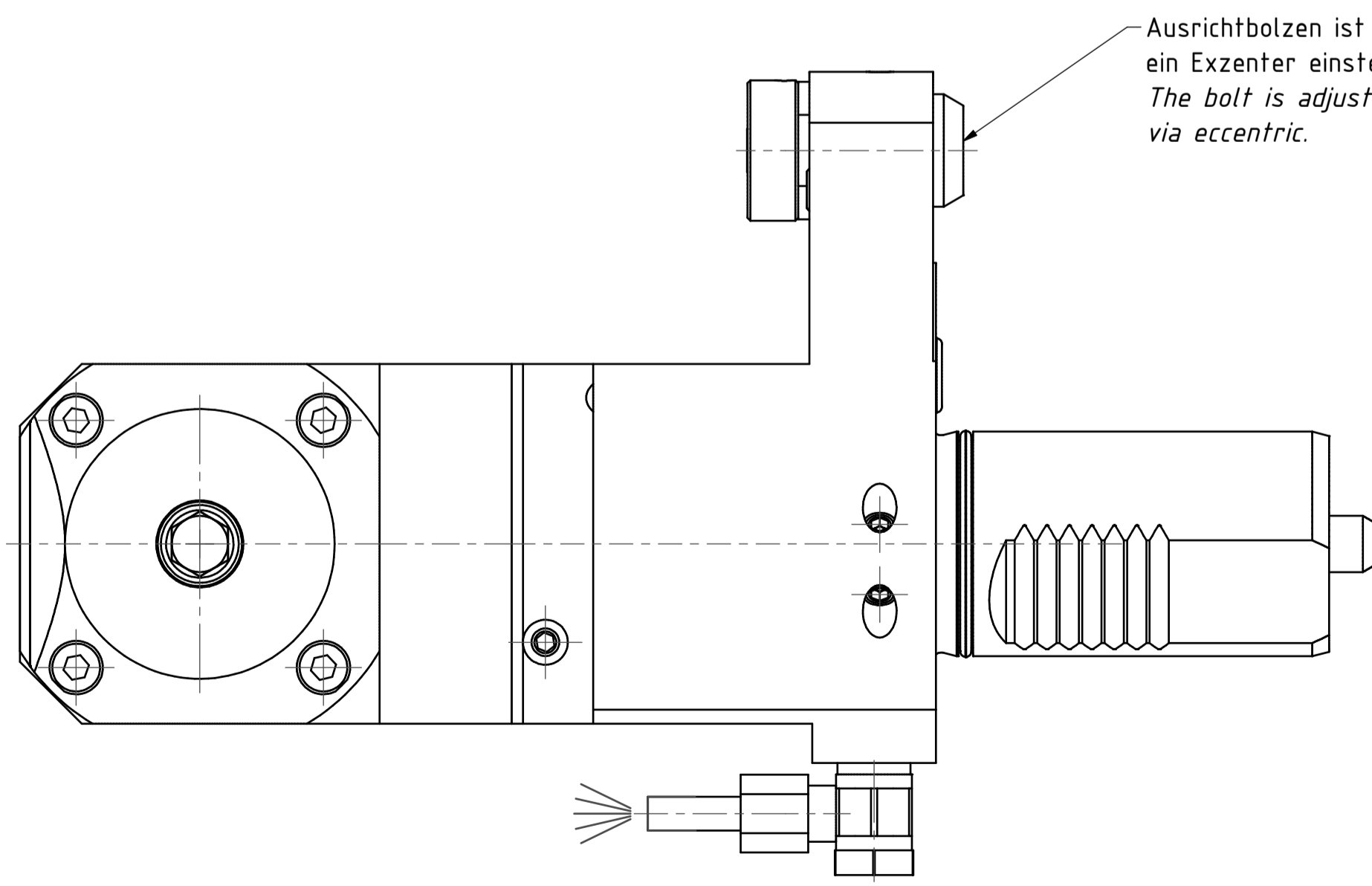

Bemerkung - Note	Technische Daten - technical data	Benennung - Title	EWS Werkzeug GmbH & Co. KG Hauptstr. 1 67206 Alzenau www.ews.de	Technische Änderungen vorbehalten! Subject to technical modifications! IDENT: D-EWS-105601	REV: B/- 120132
	Weight = 6.810 [kg] Torque max. (M1/M2) = 20 / 20 [Nm] Speed max. (n1/n2) = 6000 / 6000 [1/min] Gear ratio (i)=n1:n2 = 1:1				
EWS Tool Technologies 64.4022SQT15GL-BG30			Copyright EWS Tool Technologies Weitergabe und Vervielfältigung dieser Unterlage, Verwertung und Mitteilung ihres Inhalts nicht gestattet, soweit nicht ausdrücklich zugestanden. Zuwiderhandlungen verpflichten zu Schadenersatz.		