

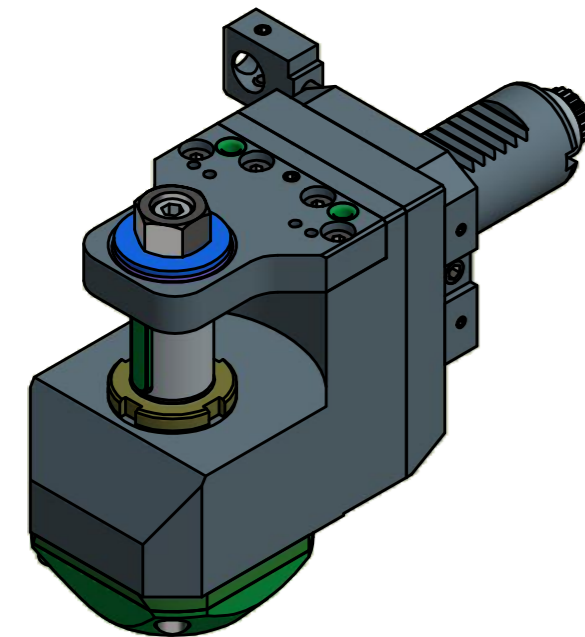

Fraeserwelle austauschbar
Spindle removable

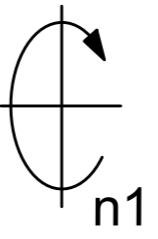
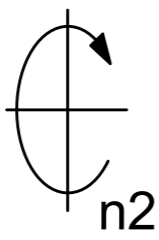

max. Fraeser-Ø80

Copyright **EWS Tool Technologies**
Weitergabe und Vervielfältigung dieser Unterlage,
Verwertung und Mitteilung ihres Inhalts nicht
gestattet, soweit nicht ausdrücklich zugestanden.
Zuwendungen verpflichten zu Schadenersatz.

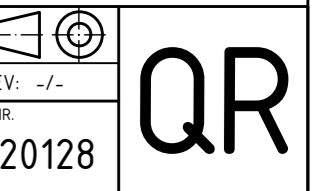
Bemerkung - Note 	Technische Daten - technical data Weight = 3.923 [kg] Torque max. (M1/M2) = 20 / 20 [Nm] Speed max. (n1/n2) = 6000 / 6000 [1/min] Gear ratio (i)=n1:n2 = 1:1	Benennung - Title Scheibenfräserkopf <i>Radial saw milling head</i>	 EWS Weigle GmbH & Co. KG Maybachstr. 1 D-73066 Uhlingen www.ews-tool.de Technische Änderungen vorbehalten! Subject to technical modifications! IDENT: D-EWS-105574 Nr. - No. 64.3022CTXGL MNR. 120128	
----------------------	--	--	--	---