

Spannzange / collet ER32 DIN6499  
Spannbereich / clamping range: 2,0 - 20,0

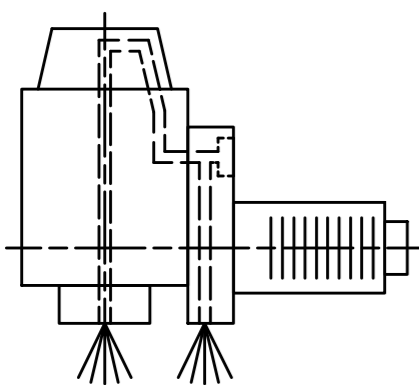

Innen- und Aussenkuehlung / Inside and outside coolant supply  
Kuehlmittelfiltrierung <math>< 50\mu</math> / coolant filtration <math>< 50\mu</math>

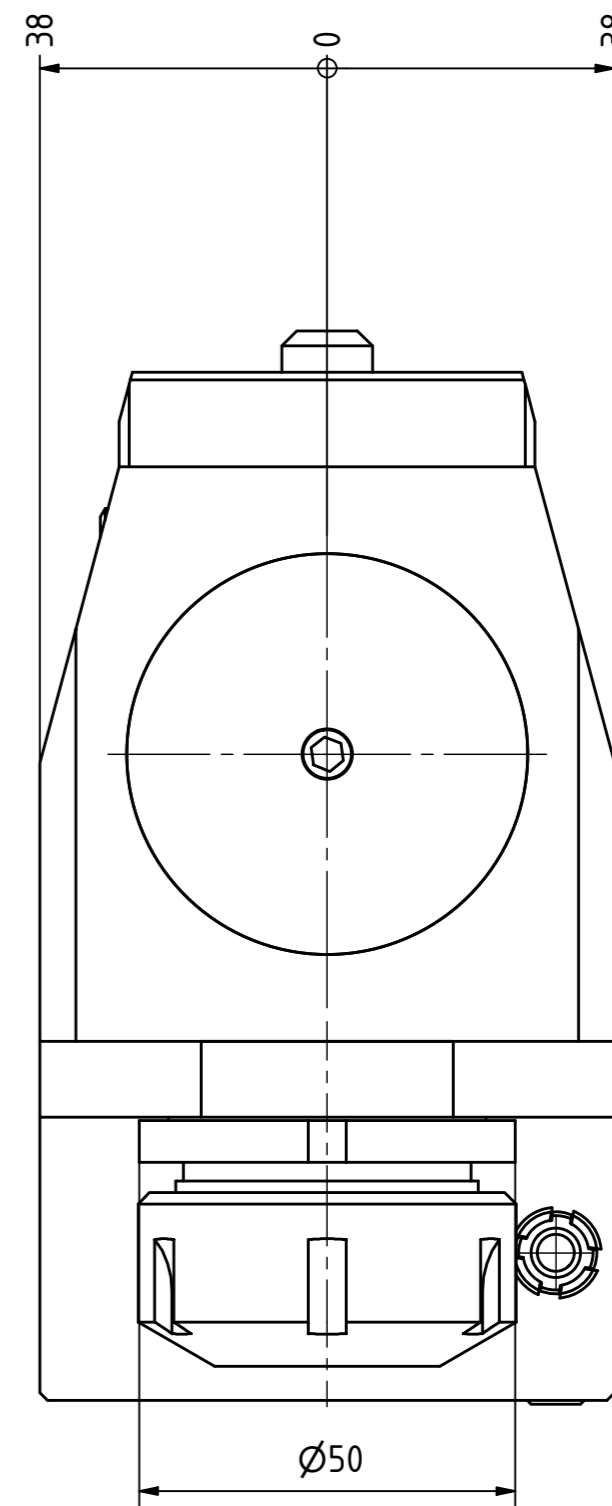
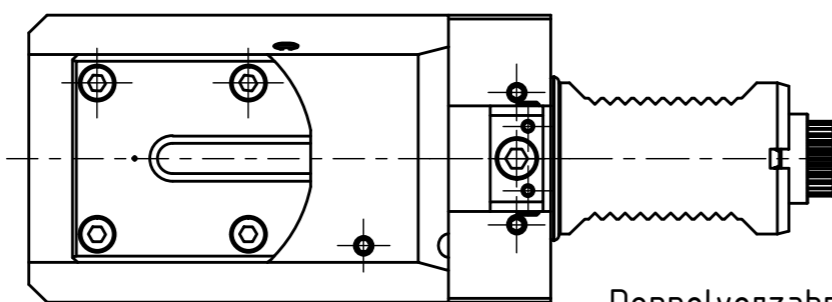

Doppelverzahnung Lizenz Traub  
double tooth system licence Traub

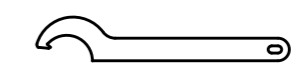
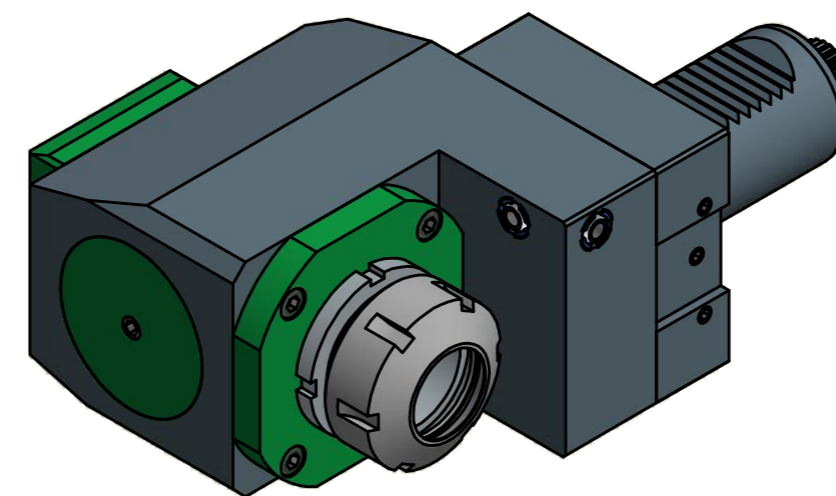

Hakenschlüssel  
mit Nase  
Hook wrench with  
nose end  
DIN1810 A 45x50



Spannzangenschlüssel  
Clamping wrench  
232

Copyright **EWS Tool Technologies**  
Weitergabe und Vervielfaeltigung dieser Unterlage,  
Verwertung und Mitteilung ihres Inhalts nicht  
gestattet, soweit nicht ausdrecklich zugestanden.  
Zuwoerhandlungen verpflichten zu Schadenersatz.

Bemerkung - Note  
Für Trockenlauf geeignet!  
Use without coolant fluid allowed!

Technische Daten - technical data  
Weight = 6.888 [kg]  
Torque max. (M1/M2) = 50 / 50 [Nm]  
Speed max. (n1/n2) = 6000 / 6000 [1/min]  
Gear ratio (i)=n1:n2 = 1:1  
Pressure (pmax) = [bar]

Benennung - Title  
Radial Bohr und Fräskopf, zurückges  
Radial drill. and mill. head offset

**EWS** Tool Technologies  
EWS Weigle GmbH & Co. KG  
Maybachstr. 1  
D-73066 Uhlingen  
www.ews-tool.de  
Nr. - No.  
80.4032CTXRLIKD

Technische Aenderungen vorbehalten!  
Subject to technical modifications!  
IDENT: D-EWS-065032  
REV: -/-

MNR.  
118983

