

Spannzange / collet ER40 DIN6499  
Spannbereich / clamping range: 3,0 - 26,0

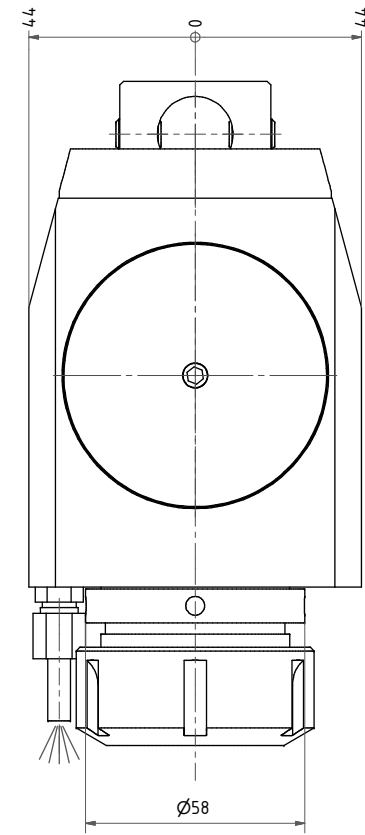

Gewindebohrzange / tapping collet  
ET-1-40 M6-M16

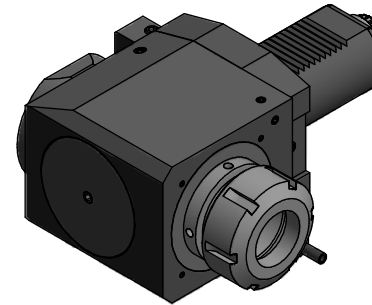

Hakenschlüssel  
mit Zapfen  
Hook wrench  
with fixed pin  
DIN1810 B 58x62

Spannzangenschlüssel  
Clamping wrench  
240

Copyright EWS Tool Technologies  
Weitergabe und Vervielfältigung dieser Unterlage,  
Verwertung und Mitteilung ihres Inhalts nicht  
gestattet, soweit nicht ausdrücklich zugestanden.  
Zuwendungen verpflichten zu Schadenersatz.

Bemerkung - Note	Technische Daten - Technical data Weight = 8.347 [kg] Torque max. (M1/M2) = 100 / 100 [Nm] Speed max. (n1/n2) = 4.000 / 4.000 [1/min] Gear ratio (i)=n1:n2 = 1:1	Benennung - Title <b>Radial Bohr und Fräskopf</b> <b>Radial drilling and milling head</b>	 EWS Werkzeug GmbH & Co. KG D-72086 Löhningen www.ews-tool.de Nr. - No. <b>60.50405480RGL</b>	Technische Änderungen vorbehalten! Subject to technical modifications! IDENT: DEWS04-0110 REV: -/A 1/18 <b>117473</b>	
------------------	--	---	---	--	---