

Hakenschlüssel  
mit Zapfen  
Hook wrench  
with fixed pin  
DIN1810 B 45x50

Spannzangenschlüssel  
Clamping wrench  
232

n2 Spannzange / collet ER32 DIN6499  
Spannbereich / clamping range: 2,0 - 20,0  
Gewindebohrzange / tapping collet  
ET-1-32 M5-M12

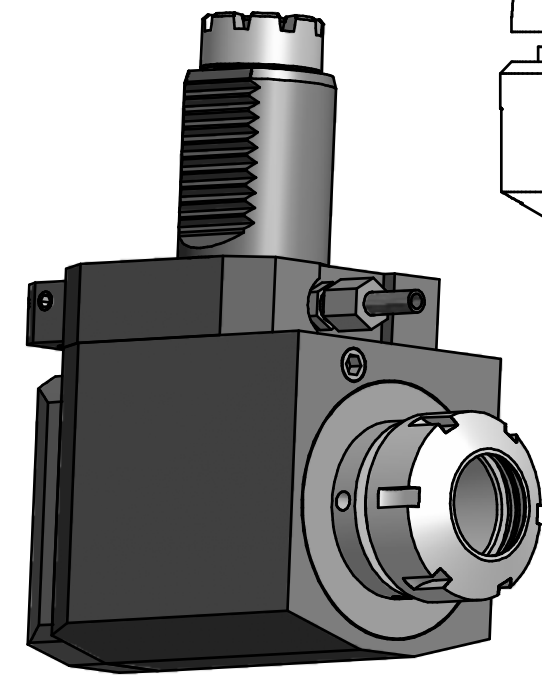

Copyright **EWS Tool Technologies**  
Weitergabe und Vervielfaeltigung dieser Unterlage,  
Verwertung und Mitteilung ihres Inhalts nicht  
gestattet, soweit nicht ausdruücklich zugestanden.  
Zuwoiderhandlungen verpflichten zu Schadenersatz.

Bemerkung - Note	Technische Daten - technical data M1 / M2 = 40 / 80 Nm n1 / n2 = 6000 / 3000 1/min i (N1:N2) = 2:1	Benennung - Title <b>Radial Bohr und Fräskopf</b> <i>Radial drilling and milling head</i>	<table border="1"> <tr> <th>name</th> <th>date</th> </tr> <tr> <td>drawing</td> <td>26.02.2007</td> </tr> </table>	name	date	drawing	26.02.2007	Technische Aenderungen vorbehalten! Subject to technical modifications! Nr. <b>60.4032TOEMRI2</b> File: 60.4032TOEMI2_OUT.idw	DIN A3 Blatt - page 1 (1)
name	date								
drawing	26.02.2007								