

Spannzange / Collet ER16 DIN6499
Spannbereich / Clamping range: 1,0 - 10,0

Gewindebohrzange / Tapping Collet
ET-1-16 M1-M6

Fettschmierung mit Klüber Isoplex NCA 15
Alle 100 Betriebsstunden mit ca. 1cm³ Fett nachschmieren
Grease lubrication with Klüber Isoplex NCA 15
relubricate every 100 operating hours with about 1cm³ of grease

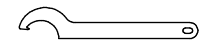
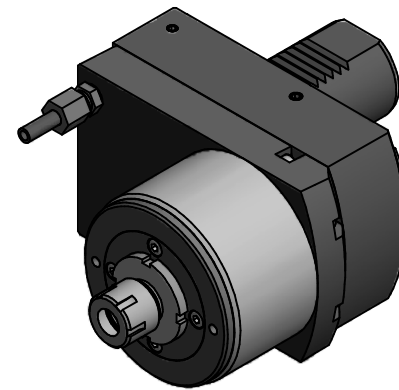

Hakenschlüssel
mit Nase
Hook wrench with
nose end
DIN1810 A 36x38

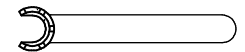

Spannzangenschlüssel
Clamping wrench
216 M

Copyright **EWS Tool Technologies**
Weitergabe und Vervielfältigung dieser Unterlage,
Verwertung und Mitteilung ihres Inhalts nicht
gestattet, soweit nicht ausdrücklich zugestanden.
Zuwerhandlungen verpflichten zu Schadenersatz.

Bemerkung - Note

Technische Daten - technical data

Weight = 5.403 [kg]
Torque max. (M1/M2) = 25 / 5 [Nm]
Speed max. (n1/n2) = 4800 / 24000 [1/min]
Gear ratio (i)=n1:n2 = 1:5

Benennung - Title

Axial Bohr u. Fräskopf achsversetzt
Ax. drill. and mill. head offset



Nr. - No.

50.4016MP610R115



MNR.

117367

Technische Änderungen vorbehalten!
Subject to technical modifications!

IDENT: DEWS003110

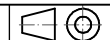

REV: -/A

MNR.

117367

