

Spannzange / collet ER25 DIN6499
 Spannbereich / clamping range: 1,0 - 16,0

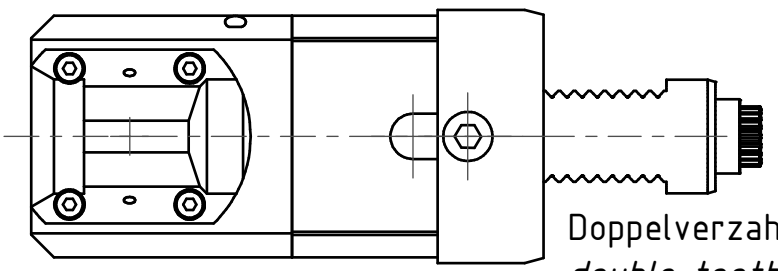
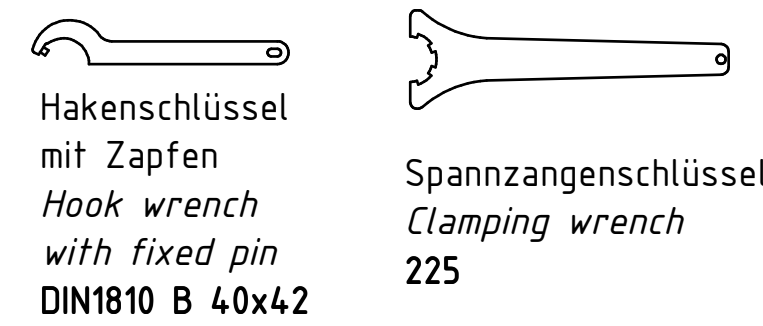
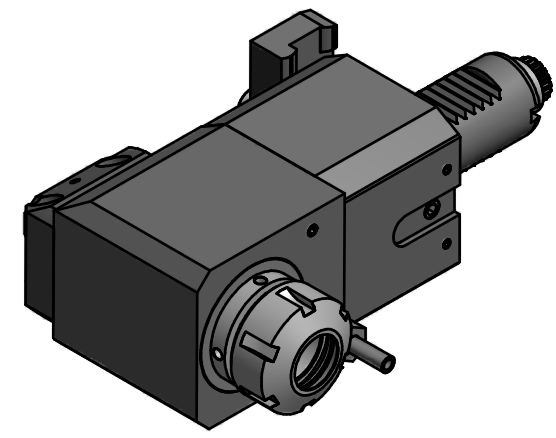

Doppelverzahnung Lizenz Traub
 double tooth system licence Traub

Innen- und Aussenkuehlung / Inside and outside coolant supply
 Kein Trockenlauf / No dry run
 Kuehlmittelfiltrierung <math>< 50\mu</math> / coolant filtration <math>< 50\mu</math>

Copyright **EWS Tool Technologies**
 Weitergabe und Vervielfaeltigung dieser Unterlage,
 Verwertung und Mitteilung ihres Inhalts nicht
 gestattet, soweit nicht ausdruuecklich zugestanden.
 Zuwiderhandlungen verpflichten zu Schadenersatz.

Bemerkung - Note Nicht ohne Kuehlmittel betreiben! Not for use without coolant-fluid!	Technische Daten - technical data M1 / M2 = 25 / 25 Nm n1 / n2 = 8000 / 8000 1/min i (N1:N2) = 1:1 pmax = 70 bar	Benennung - Title Radial Bohr und Fräskopf <i>Radial drilling and milling head</i>	name	date	Technische Aenderungen vorbehalten! Subject to technical modifications!	
			drawing	Kratschmann		
			EWS Weigete GmbH & Co. KG Maybachstr. 1 D-73066 Uhingen Tel. +49(0)7161/93040-100		Nr. 60.3025E365RLIKOT13	DIN A3
			MNR: 116289		IDENT: D-EWS-075670 A	Blatt - page 1 (1)