

Spannzange / collet ER32 DIN6499
 Spannungsbereich / clamping range: 2,0 - 20,0

Gewindebohrzange / tapping collet
 ET-1-32 M5-M12

 Spannzangenschlüssel
 Clamping wrench
 232

 Hakenschlüssel
 mit Zapfen
 Hook wrench
 with fixed pin
 DIN1810 B 45x50

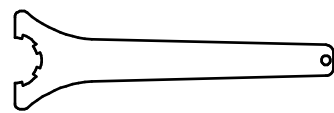
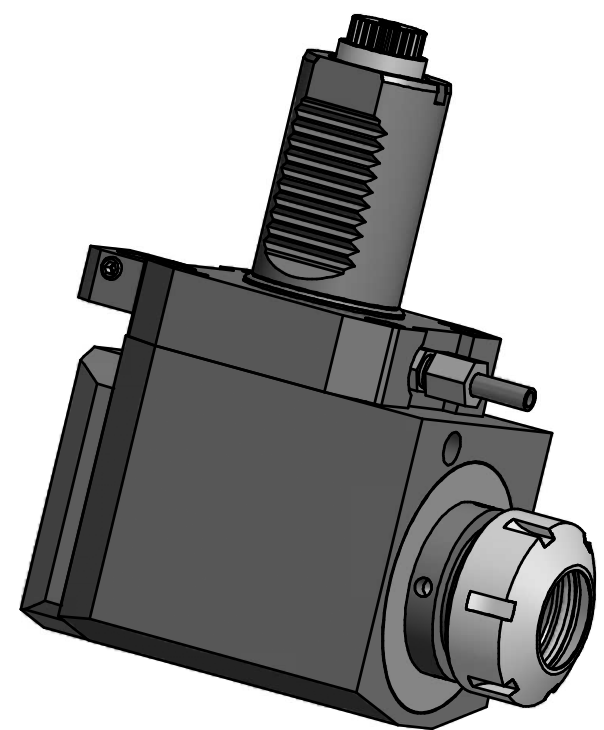

Copyright **EWS Tool Technologies**
 Weitergabe und Vervielfaeltigung dieser Unterlage,
 Verwertung und Mitteilung ihres Inhalts nicht
 gestattet, soweit nicht ausdrecklich zugestanden.
 Zuwiderhandlungen verpflichten zu Schadenersatz.

Bemerkung - Note	Technische Daten - technical data M1 / M2 = 40 / 80 Nm n1 / n2 = 6000 / 3000 1/min i (N1:N2) = 2:1	Benennung - Title Radial Bohr und Fräskopf Radial drilling and milling head	<table border="1"> <tr> <th>name</th> <th>date</th> </tr> <tr> <td>Theiss</td> <td>20.09.2011</td> </tr> </table>  Weigele GmbH & Co. KG Maybachstr. 1 D-73066 UHINGEN Tel. +49(0)7161/93040-10	name	date	Theiss	20.09.2011	Technische Aenderungen vorbehalten! Subject to technical modifications! Nr. 60.4032KCTXR12 File: D-EWS-109396-.idw Blatt - page 1 (1)
name	date							
Theiss	20.09.2011							