

Doppelverzahnung Lizenz Traub
double tooth system licence Traub

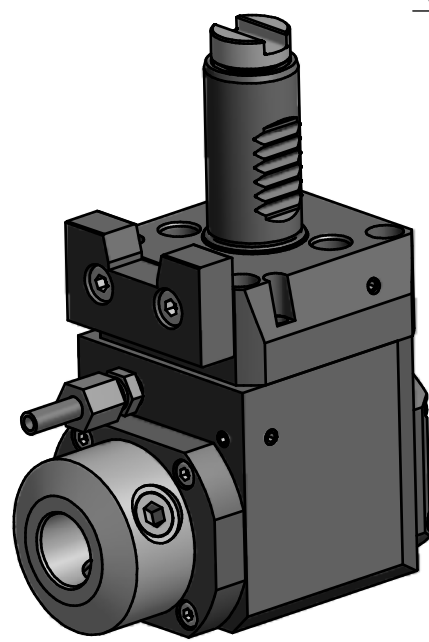

Copyright **EWS Tool Technologies**
 Weitergabe und Vervielfaeltigung dieser Unterlage,
 Verwertung und Mitteilung ihres Inhalts nicht
 gestattet, soweit nicht ausdrecklich zugestanden.
 Zuwiderhandlungen verpflichten zu Schadenersatz.

| | | | | | | |
|------------------|---|---|---|------|---|--------|
| Bemerkung - Note | Technische Daten - technical data $M1 / M2 = 40 / 80 \text{ Nm}$ $n1 / n2 = 6000 / 3000 \text{ 1/min}$ $i (N1:N2) = 2:1$ | Benennung - Title Radial Bohr und Fräskopf <i>Radial drilling and milling head</i> | name | date | Technische Aenderungen vorbehalten! <i>Subject to technical modifications!</i> | |
| | | | drawing | Seeh | | |
| | | | Weigele GmbH & Co. KG Maybachstr. 1 D-73066 UHINGEN Tel. +49(0)7161/93040-10 | | Nr. 60.2520WNG200RLI2V | DIN A3 |
| | | | MNR: 117315 IDENT: D-EWS-059781 - | | Blatt - page 1 (1) | |