

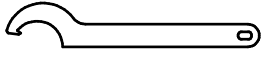
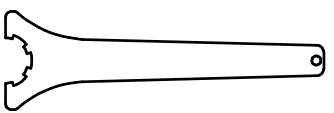
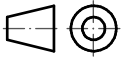

Spannzange / collet ER25 DIN6499
 Spannbereich / clamping range: 1,0 - 16,0

Gewindebohrzange / tapping collet
 ET-1-25 M3-M10

-  Hakenschlüssel mit Nase
Hook wrench with nose end
DIN1810 A 45x50
-  Spannzangenschlüssel
Clamping wrench
225

Copyright **EWS Tool Technologies**
 Weitergabe und Vervielfaeltigung dieser Unterlage,
 Verwertung und Mitteilung ihres Inhalts nicht
 gestattet, soweit nicht ausdrecklich zugestanden.
 Zuwiderhandlungen verpflichten zu Schadenersatz.

Bemerkung - Note	Technische Daten - technical data M1 / M2 = 20 / 20 Nm n1 / n2 = 6000 / 6000 1/min i (N1:N2) = 1:1	Benennung - Title Schwenkkopf <i>Swivel head</i>	name	date	Technische Aenderungen vorbehalten! Subject to technical modifications!	 Nr. 63.4025MT20 File: 63.4025MT25_OUT.idw
			drawing	Kratschmann		
			 Weigle GmbH & Co. KG Maybachstr. 1 D-73066 Uehingen Tel. +49(0)7161/93040-10		Blatt - page 1 (1)	