

Schwenkbereich $\pm 115^\circ$
Swivel area $\pm 115^\circ$

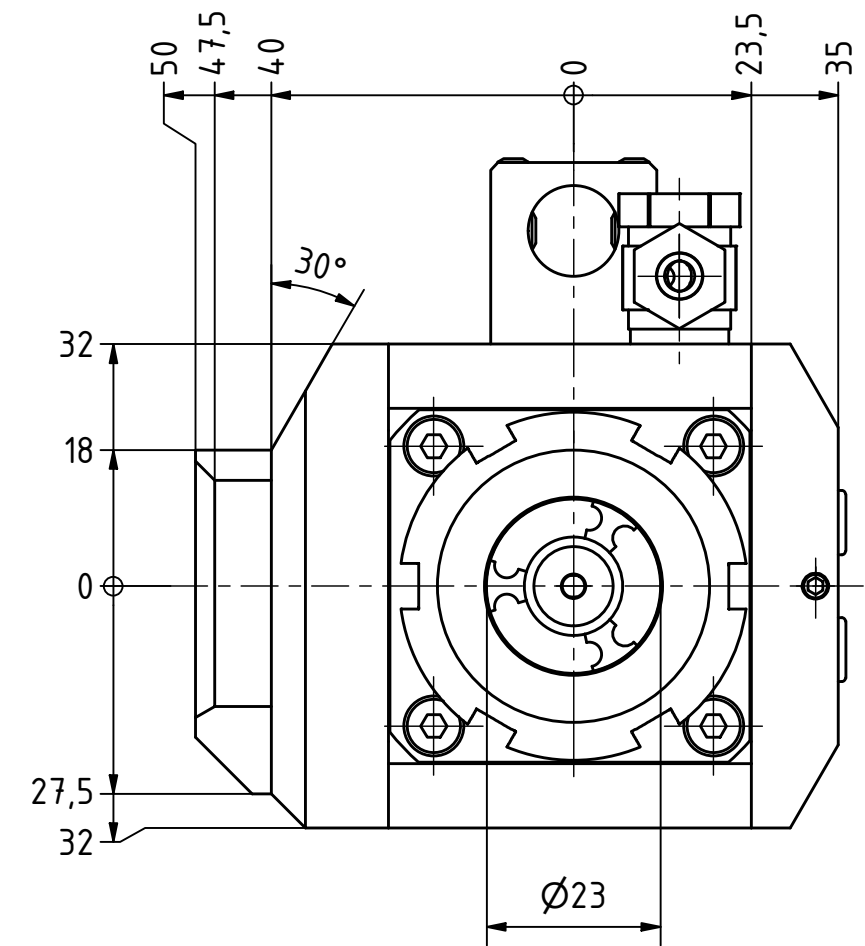

Spannzange / Collet ER16 DIN6499
Spannbereich / Clamping range: 1,0 - 10,0

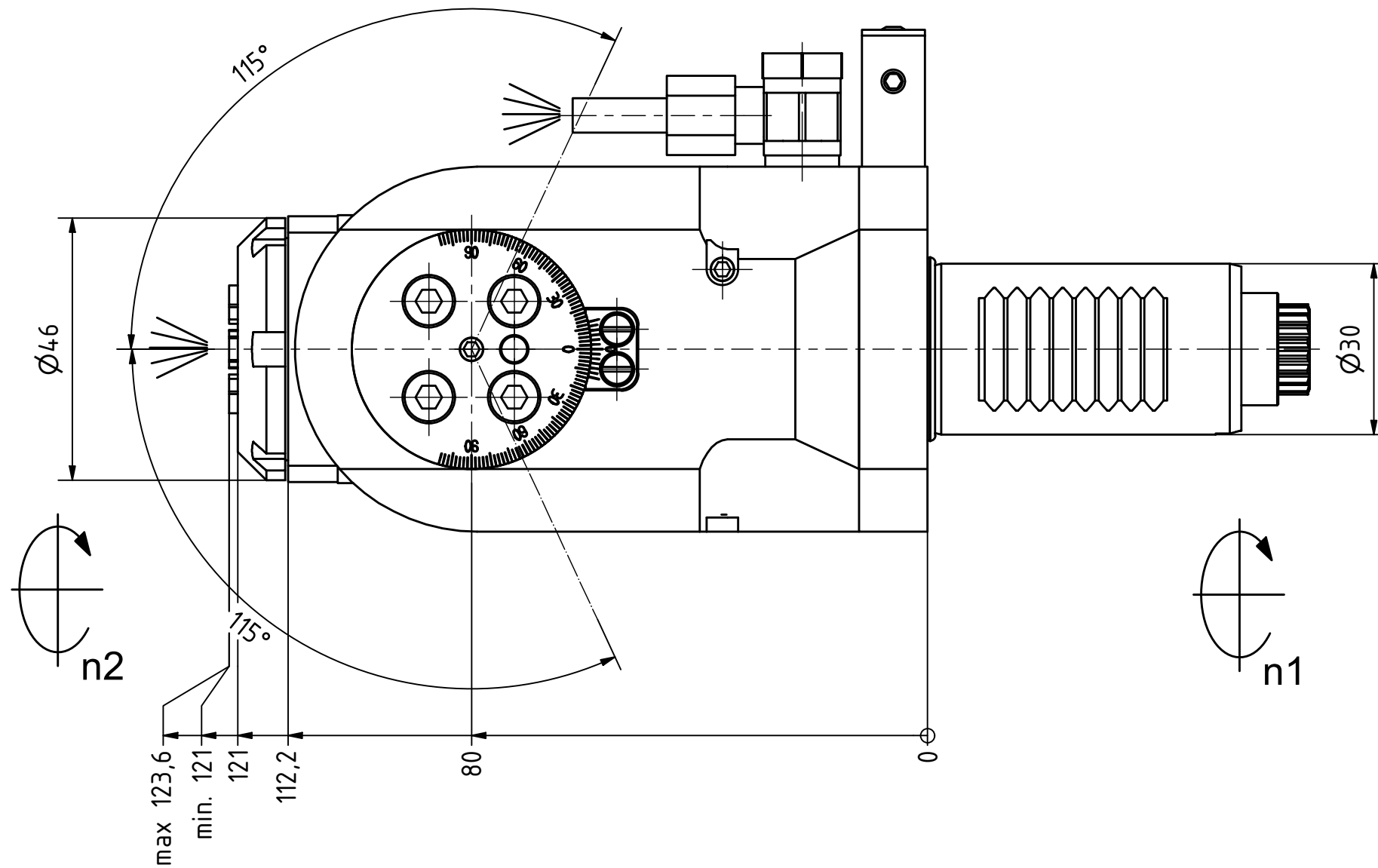
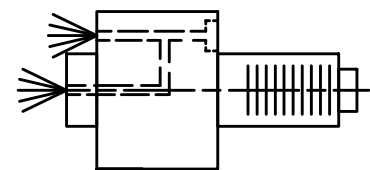

Innen- und Aussenkuehlung / Inside and outside coolant supply
Kuehlmittelfiltrierung 50μ / coolant filtration 50μ

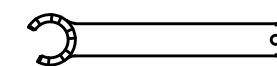
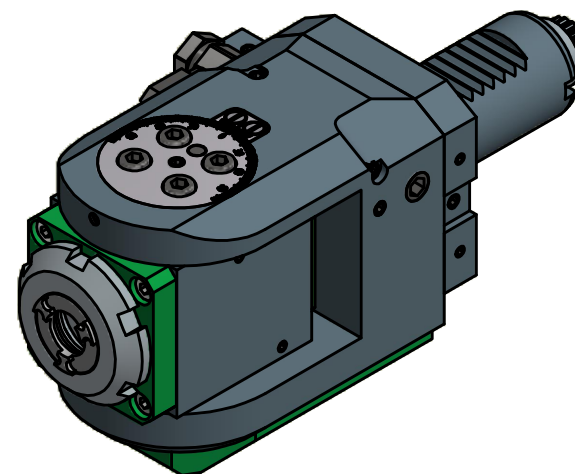

Spannzangenschlüssel für
innenliegende Mutter
Clamping wrench for
internal collet
216AX

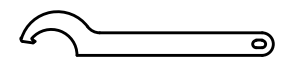

Hakenschlüssel
mit Nase
Hook wrench with
nose end
DIN1810 A 45x50

Copyright **EWS Tool Technologies**
Weitergabe und Vervielfaeltigung dieser Unterlage,
Verwertung und Mitteilung ihres Inhalts nicht
gestattet, soweit nicht ausdrecklich zugestanden.
Zuwiderhandlungen verpflichten zu Schadenersatz.

Bemerkung - Note
Für Trockenlauf geeignet!
Use without coolant fluid allowed!

Technische Daten - technical data
Weight = 3.673 [kg]
Torque max. (M1/M2) = 16 / 16 [Nm]
Speed max. (n1/n2) = 8000 / 8000 [1/min]
Gear ratio (i)=n1:n2 = 1:1
Pressure (pmax) = 70 [bar]

Benennung - Title
Schwenkkopf
Swivel head

EWS Tool Technologies
EWS Weigele GmbH & Co. KG
Maybachstr. 1
D-73066 UHINGEN
www.ews-tools.de

Technische Aenderungen vorbehalten!
Subject to technical modifications!

IDENT: D-EWS-077267

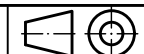

REV: -/C

Nr. - No.

63.3016CTXIKDIM

MNR.

147072

QR