

6 5 4 3 2 1

D
C
B
A

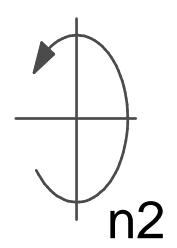
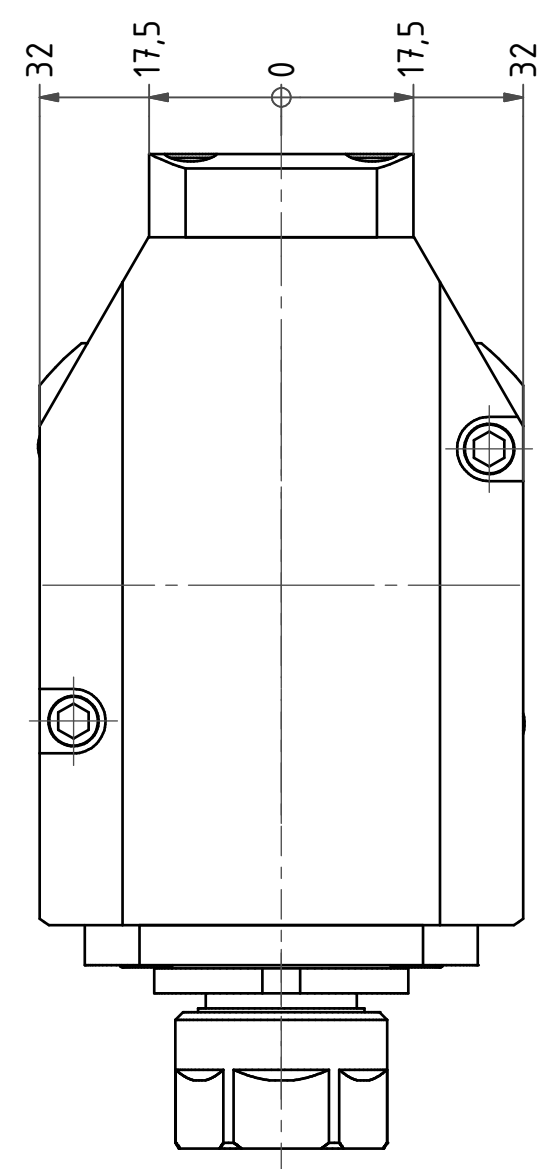
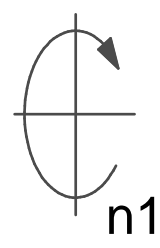
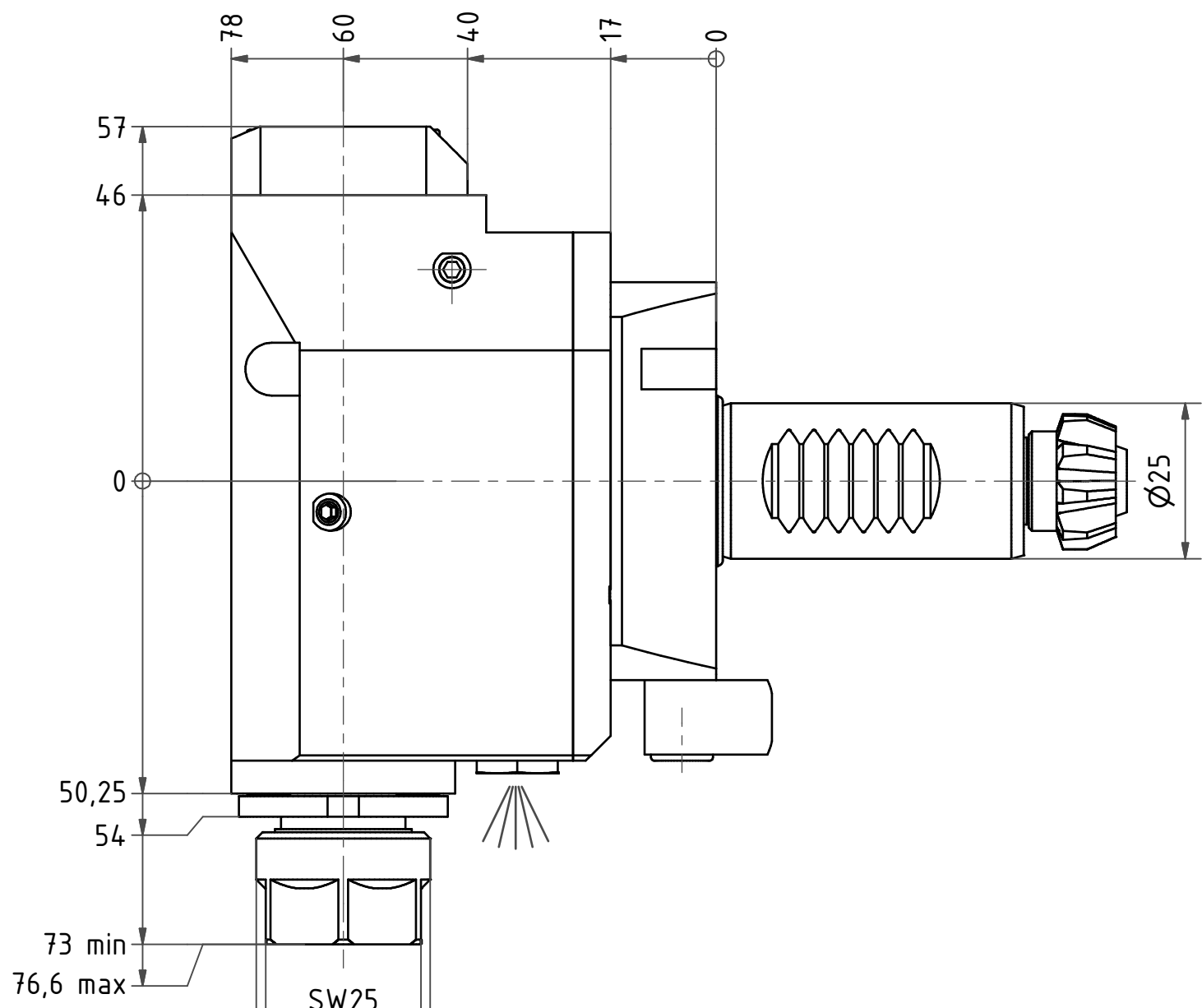

Spannzange / Collet ER16 DIN6499
Spannbereich / Clamping range: 1,0 - 10,0

Gewindebohrzange / Tapping Collet
ET-1-16 M1-M6

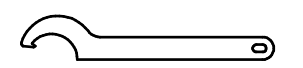
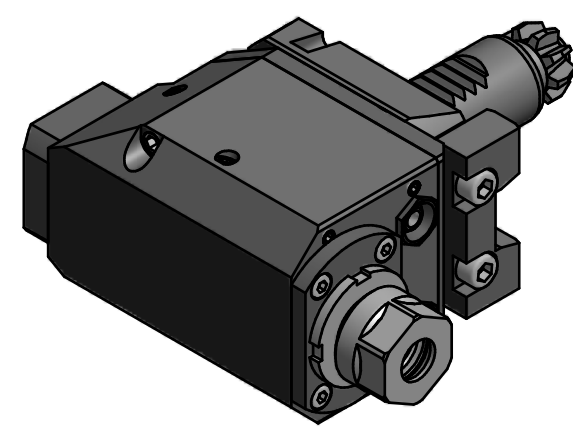

Hakenschlüssel
mit Nase
Hook wrench with
nose end
DIN1810 A 34x36

Copyright **EWS Tool Technologies**
Weitergabe und Vervielfaeltigung dieser Unterlage,
Verwertung und Mitteilung ihres Inhalts nicht
gestattet, soweit nicht ausdrecklich zugestanden.
Zuwiderhandlungen verpflichten zu Schadenersatz.

Bemerkung - Note	Technische Daten - technical data M1 / M2 = 15 / 5 Nm n1 / n2 = 6000 / 18000 1/min i (N1:N2) = 1:3	Benennung - Title Radial Bohr und Fräskopf <i>Radial drilling and milling head</i>	name	date	Technische Aenderungen vorbehalten! Subject to technical modifications!	
			drawing	Theiss		
					Nr. 60.2516ABCRI13VX60	DIN A3
			EWS Weigete GmbH & Co. KG Maybachstr. 1 D-73066 Uhingen Tel. +49(0)7161/93040-100			
			MNR: 14.7046		IDENT: D-EWS-077386 B	Blatt - page 1 (1)

6 5 4 3 2 1