

Spannzange / collet ER50 DIN6499
 Spannbereich / clamping range: 6,0 - 34,0

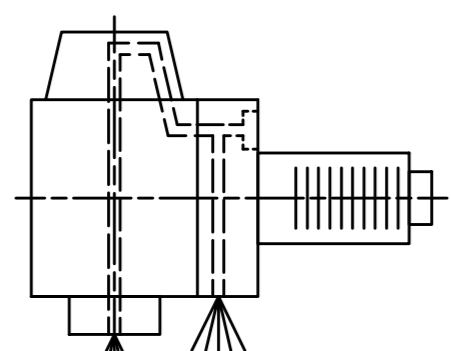

Innen- und Aussenkuehlung / Inside and outside coolant supply
 Kuehlmittelfiltrierung-50µ / coolant filtration-50µ

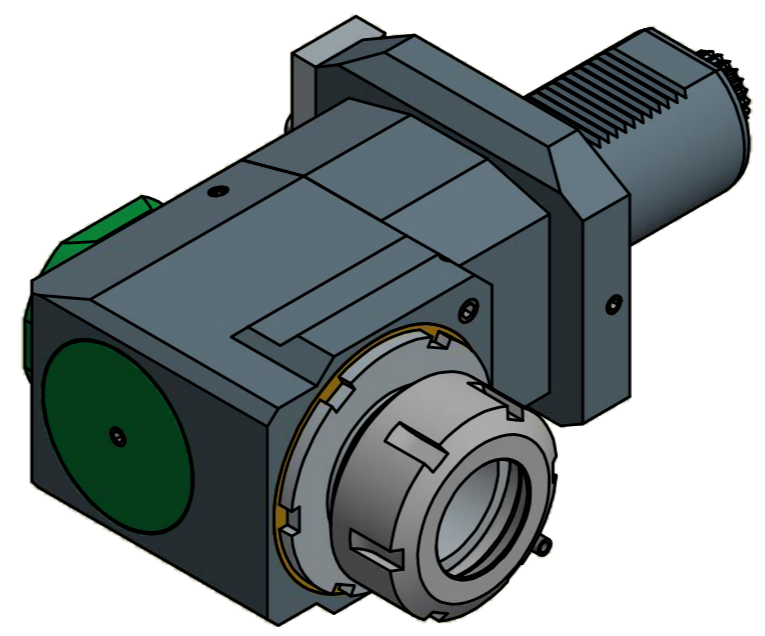

Hakenschlüssel mit Zapfen
 Hook wrench with fixed pin
 DIN1810 B 80x90

Spannzangenschlüssel
 Clamping wrench
 250

Copyright **EWS Tool Technologies**
 Weitergabe und Vervielfaeltigung dieser Unterlage, Verwertung und Mitteilung ihres Inhalts nicht gestattet, soweit nicht ausdrecklich zugestanden. Zuwiderhandlungen verpflichten zu Schadenersatz.

<p>Bemerkung - Note Für Trockenlauf geeignet! Use without coolant fluid allowed!</p>	<p>Technische Daten - technical data Weight = 14.596 [kg] Torque max. (M1/M2) = 160 / 160 [Nm] Speed max. (n1/n2) = 3000 / 3000 [1/min] Gear ratio (i)=n1:n2 = 1:1 Pressure (pmax) = 70 [bar]</p>	<p>Benennung - Title Radial Bohr und Fräskopf Radial drilling and milling head</p>	<p>EWS Tool Technologies EWS Weigle GmbH & Co. KG Maybachstr. 1 D-73066 Uhlingen www.ews-tools.de</p>	<p>Technische Aenderungen vorbehalten! Subject to technical modifications! IDENT: D-EWS-005684 MNR.</p>	<p>Nr. - No. 60.6050DOSRIKDGL0T09-BG50 REV: -/- 145627</p>
--	--	---	--	--	---

