

Spannzange / collet ER25 DIN6499
 Spannereich / clamping range: 1,0 - 16,0

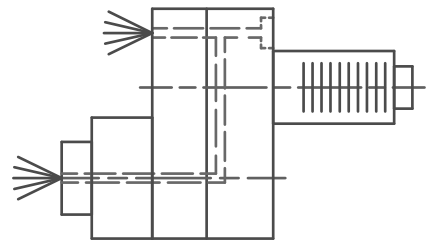

Innen- und Aussenkuehlung / Inside and outside coolant supply
 Kein Trockenlauf / No dry run
 Kuehlmittelfiltrierung <math>< 50\mu</math> / coolant filtration <math>< 50\mu</math>

Hakenschlüssel
 mit Zapfen
 Hook wrench
 with fixed pin
 DIN1810 B 45x50

Spannzangenschlüssel
 Clamping wrench
 225

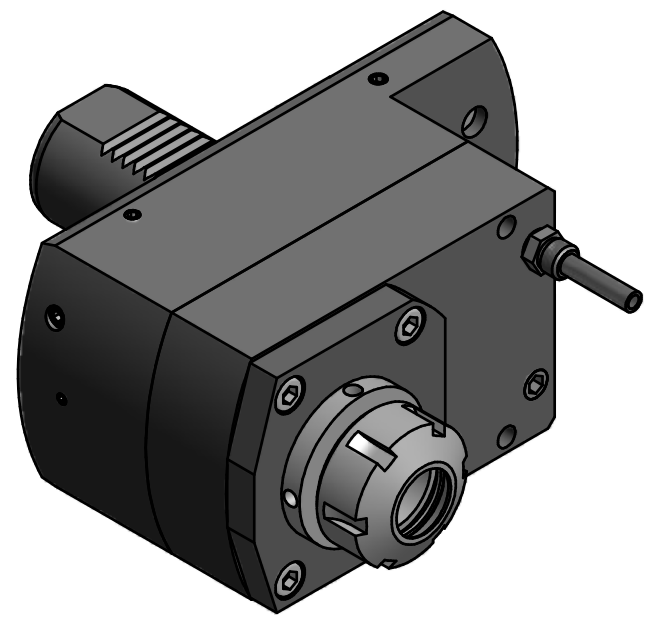

Copyright **EWS Tool Technologies**
 Weitergabe und Vervielfaeltigung dieser Unterlage,
 Verwertung und Mitteilung ihres Inhalts nicht
 gestattet, soweit nicht ausdruücklich zugestanden.
 Zuwiderhandlungen verpflichten zu Schadenersatz.

<p>Bemerkung - Note Nicht ohne Kuehlmittel betreiben! Not for use without coolant-fluid!</p>	<p>Technische Daten - technical data M1 / M2 = 50 / 50 Nm n1 / n2 = 6000 / 6000 1/min i (N1:N2) = 1:1 pmax = 70 bar</p>	<p>Benennung - Title Axial Bohr u. Fräskopf achsversetzt Ax. drill. and mill. head offset</p>	<table border="1"> <tr> <th>name</th> <th>date</th> </tr> <tr> <td>Schmid</td> <td>06.09.2010</td> </tr> </table> <p>EWS EWS Weigete GmbH & Co. KG Maybachstr. 1 D-73066 Uehingen Tel. +49(0)7161/93040-100</p>	name	date	Schmid	06.09.2010	<p>Technische Aenderungen vorbehalten! Subject to technical modifications!</p> <p>Nr. 50.4025MP610LIK</p> <p>DIN A3</p> <p>MNR: 146923 IDENT: D-EWS-093216 - Blatt - page 1 (1)</p>
name	date							
Schmid	06.09.2010							