

min. 83,5
max. 87
Ø50

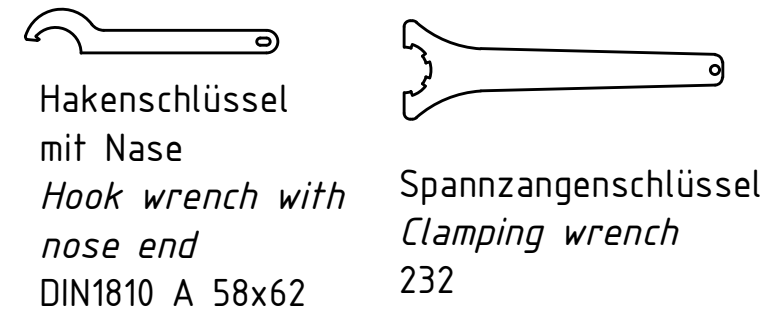
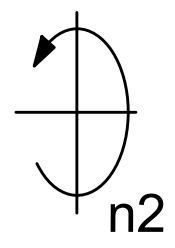

Spannzange / collet ER32 DIN6499
Spannbereich / clamping range: 2,0 - 20,0

Gewindebohrzange / tapping collet
ET-1-32 M5-M12

Copyright **EWS Tool Technologies**
Weitergabe und Vervielfaeltigung dieser Unterlage,
Verwertung und Mitteilung ihres Inhalts nicht
gestattet, soweit nicht ausdrecklich zugestanden.
Zuwiderhandlungen verpflichten zu Schadenersatz.

Bemerkung - Note	Technische Daten - technical data Weight = 8.378 [kg] Torque max. (M1/M2) = 50 / 25 [Nm] Speed max. (n1/n2) = 6000 / 12000 [1/min] Gear ratio (i)=n1:n2 1:2	Benennung - Title Radial Bohr und Fräskopf <i>Radial drilling and milling head</i>	 EWS Weigele GmbH & Co. KG Maybachstr. 1 D-73066 UHINGEN www.ews-tools.de Nr. - No. 60.4032MP620R11	Technische Aenderungen vorbehalten! Subject to technical modifications! IDENT: D-EWS-012526 MNR. 117043	 QR
------------------	---	---	--	--	---------------