

Spannzange / collet ER32 DIN6499
Spannbereich / clamping range: 2,0 - 20,0

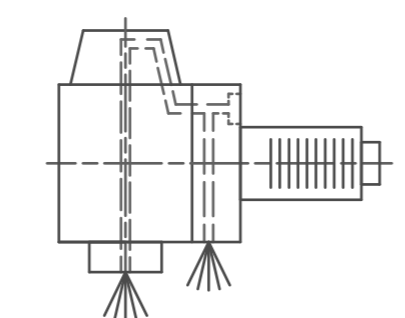
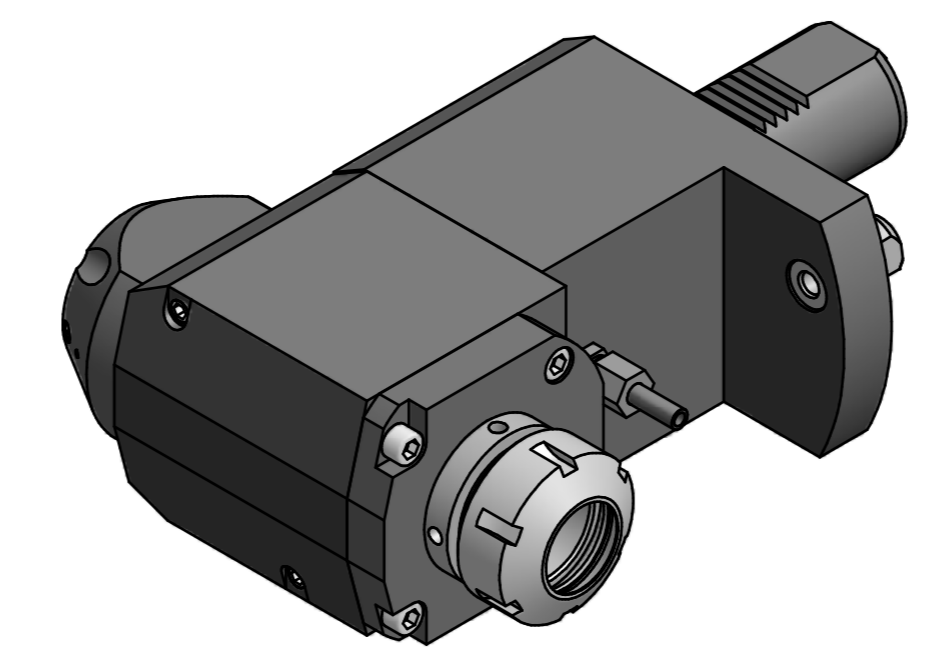

Innen- und Aussenkuehlung / Inside and outside coolant supply
Kein Trockenlauf / No dry run
Kuehlmittelfiltrierung50μ / coolant filtration50μ

Hakenschlüssel
mit Zapfen
Hook wrench
with fixed pin
DIN1810 B 45x50

Spannzangenschlüssel
Clamping wrench
232

Copyright **EWS Tool Technologies**
Weitergabe und Vervielfaeltigung dieser Unterlage,
Verwertung und Mitteilung ihres Inhalts nicht
gestattet, soweit nicht ausdruercklich zugestanden.
Zuwiderhandlungen verpflichten zu Schadenersatz.

Bemerkung - Note Nicht ohne Kuehlmittel betreiben! Not for use without coolant-fluid! mit Kegelrollenlagern with taper roller bearings	Technische Daten - Technical data $M_1 / M_2 = 50 / 50 \text{ Nm}$ $n_1 / n_2 = 5000 / 5000 \text{ 1/min}$ $i (N_1:N_2) = 1:1$ $P_{max} = 70 \text{ bar}$	Benennung - Title Radial Bohr und Fräskopf <i>Radial drilling and milling head</i>	name Kraftschmann	date 08.01.2009	Technische Aenderungen vorbehalten! Subject to technical modifications! Nr. 60.4032KRMP620RIK <small>EWS Werkzeug GmbH & Co. KG Mühlbacherstr. 1 D-73066 Ulm/Donau Tel. +49(0)716193040-100</small>	IDENT: D-EWS-070339 A Blatt - page 1 (1)
			drawing	MNR: 145348		

