

Spannzange / collet ER40 DIN6499  
 Spannungsbereich / clamping range: 3,0 - 26,0

Gewindebohrzange / tapping collet  
 ET-1-40 M6-M16

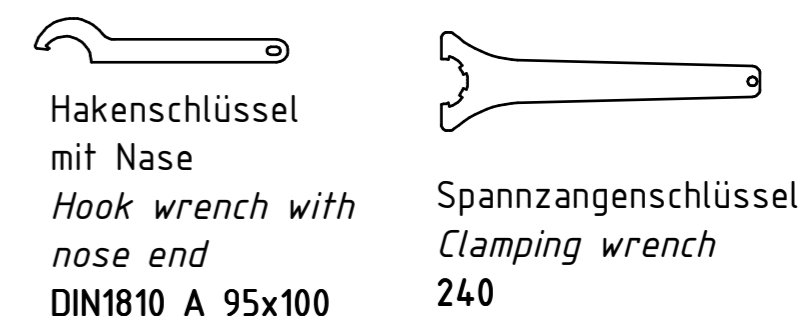
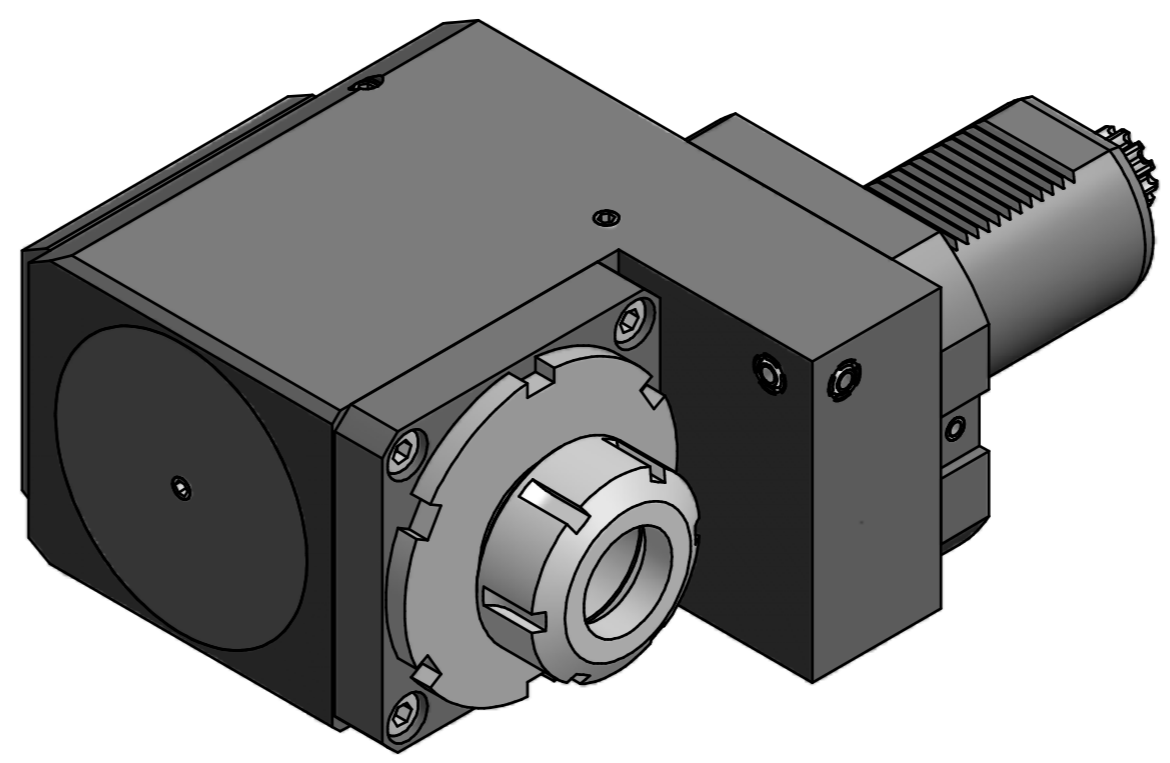

Copyright **EWS Tool Technologies**  
 Weitergabe und Vervielfältigung dieser Unterlage,  
 Verwertung und Mitteilung ihres Inhalts nicht  
 gestattet, soweit nicht ausdrücklich zugestanden.  
 Zuwiderhandlungen verpflichten zu Schadenersatz.

Bemerkung - Note mit Kegelrollenlagern with taper roller bearings	Technische Daten - Technical data M <sub>1</sub> / M <sub>2</sub> = 160 / 160 Nm n <sub>1</sub> / n <sub>2</sub> = 3000 / 3000 1/min i (N <sub>1</sub> :N <sub>2</sub> ) = 1:1	Benennung - Title <b>Radial Bohr und Fräskopf. zurückges</b> <b>Radial drill. and mill. head offset</b>	name	date	Technische Änderungen vorbehalten! Subject to technical modifications!
			drawing	Theiss	
			<b>EWS</b> Werkzeug GmbH & Co. KG <small>Maybachstr. 1        D-73066 Ulm/ingen        Tel. +49(0)7161/93040-100</small>		Nr. <b>80.6040KR5482R</b>
			MNR: 115890		IDENT: D-EWS-047387 - Blatt - page 1 (1)

