

min. 32
max. 35,5
38

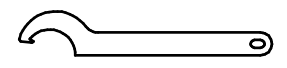

Hakenschlüssel
mit Nase
Hook wrench with
nose end
DIN1810 A 45x50

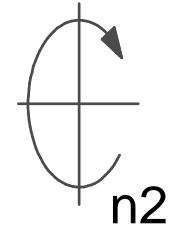
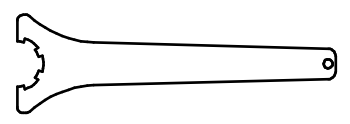

Spannzangenschlüssel
Clamping wrench
225

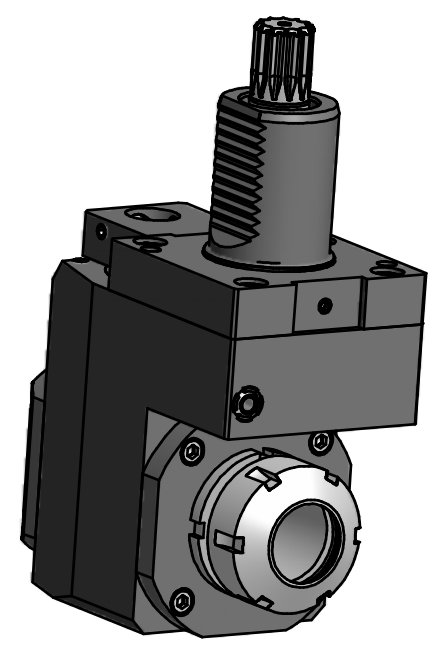

Spannzange / collet ER32 DIN6499
Spannbereich / clamping range: 2,0 - 20,0

Gewindebohrzange / tapping collet
ET-1-32 M5-M12

Copyright **EWS Tool Technologies**
Weitergabe und Vervielfaeltigung dieser Unterlage,
Verwertung und Mitteilung ihres Inhalts nicht
gestattet, soweit nicht ausdrecklich zugestanden.
Zuwiderhandlungen verpflichten zu Schadenersatz.

Bemerkung - Note	Technische Daten - technical data $M1 / M2 = 50 / 50 \text{ Nm}$ $n1 / n2 = 5000 / 5000 \text{ 1/min}$ $i (N1:N2) = 1:1$	Benennung - Title Radial Bohr und Fräskopf. zurückges Radial drill. and mill. head offset	<table border="1"> <tr> <td>name</td> <td>date</td> </tr> <tr> <td>Schmid</td> <td>14.01.2008</td> </tr> </table>	name	date	Schmid	14.01.2008	Technische Aenderungen vorbehalten! Subject to technical modifications! Nr. 80.403254822017R	
name	date								
Schmid	14.01.2008								
MNR: 114395 IDENT: D-EWS-055096 -		Blatt - page 1 (1)							