

Spannzange / collet ER40 DIN6499
Spannbereich / clamping range: 3,0 - 26,0

Gewindebohrzange / tapping collet
ET-1-40 M6-M16

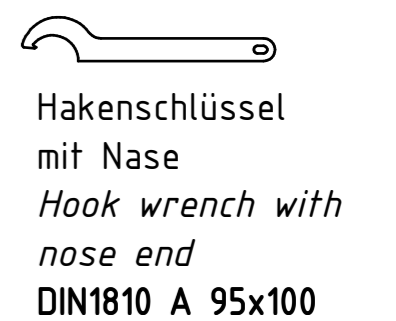
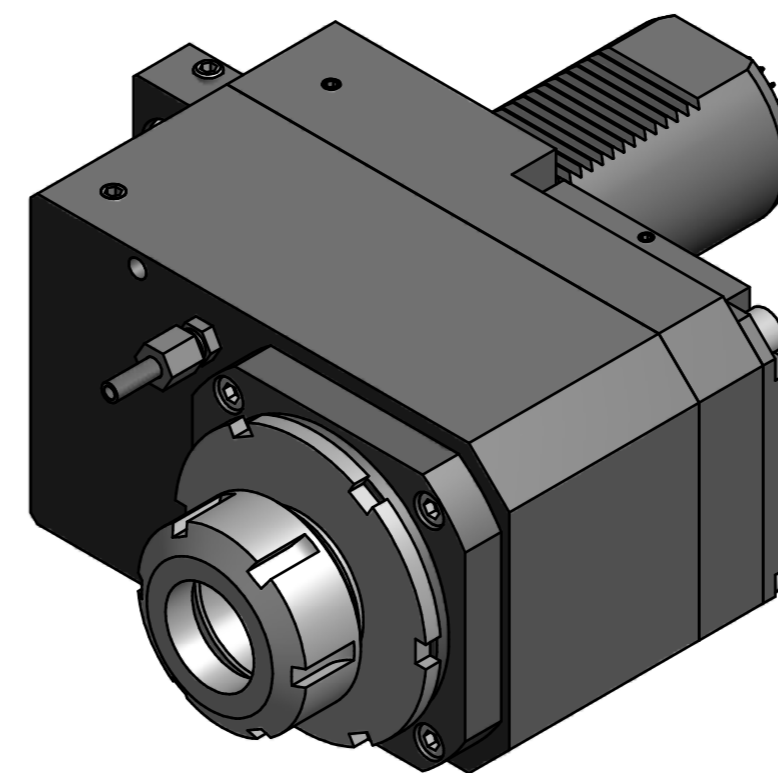

Copyright **EWS Tool Technologies**
Weitergabe und Vervielfältigung dieser Unterlage,
Verwertung und Mitteilung ihres Inhalts nicht
gestattet, soweit nicht ausdrücklich zugestanden.
Zuwerhandlungen verpflichten zu Schadenersatz.

Bemerkung - Note

mit Kegelrollenlagern
with taper roller bearings

Technische Daten - technical data

Weight = 18.500 [kg]
Torque max. (M1/M2) = 80 / 160 [Nm]
Speed max. (n1/n2) = 4.000 / 2000 [1/min]
Gear ratio (i)=n1:n2 = 2:1

Benennung - Title

Axial Bohr u. Fräskopf achsversetzt
Ax. drill. and mill. head offset



Nr. - No.
50.6040KR5482R12

Technische Änderungen vorbehalten!
Subject to technical modifications!
IDENT: D-EWS-124392

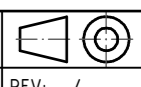

146622

