

Spannzange / collet ER25 DIN6499  
 Spannbereich / clamping range: 1,0 - 16,0

Gewindebohrzange / tapping collet  
 ET-1-25 M3-M10

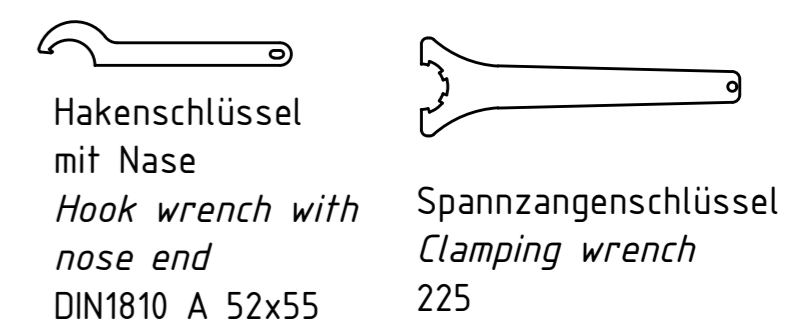
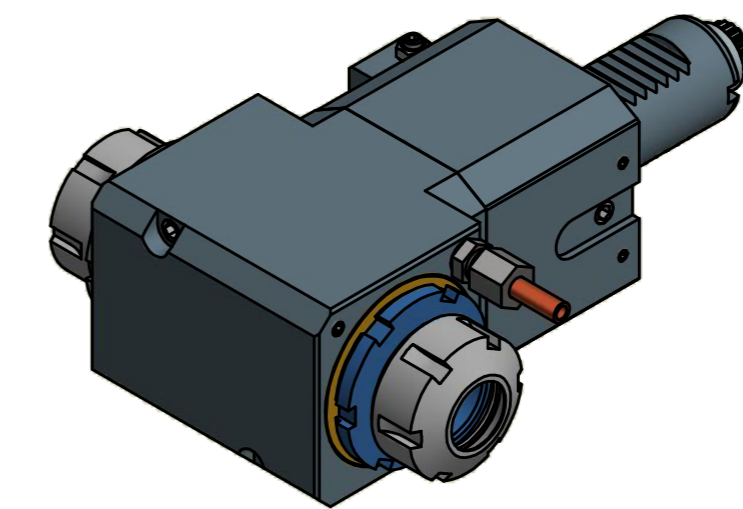
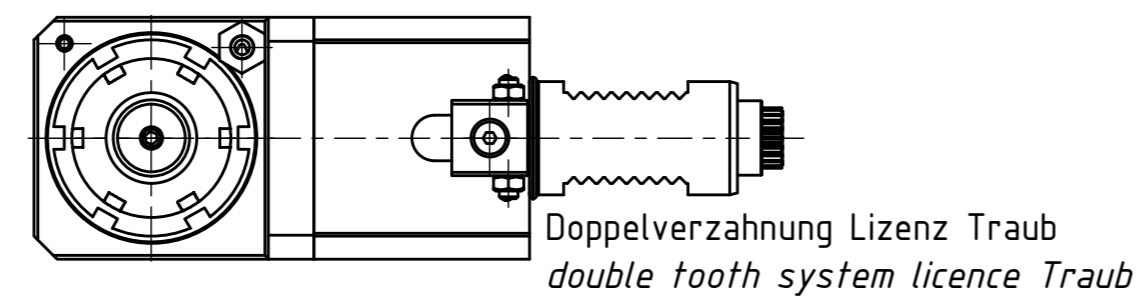
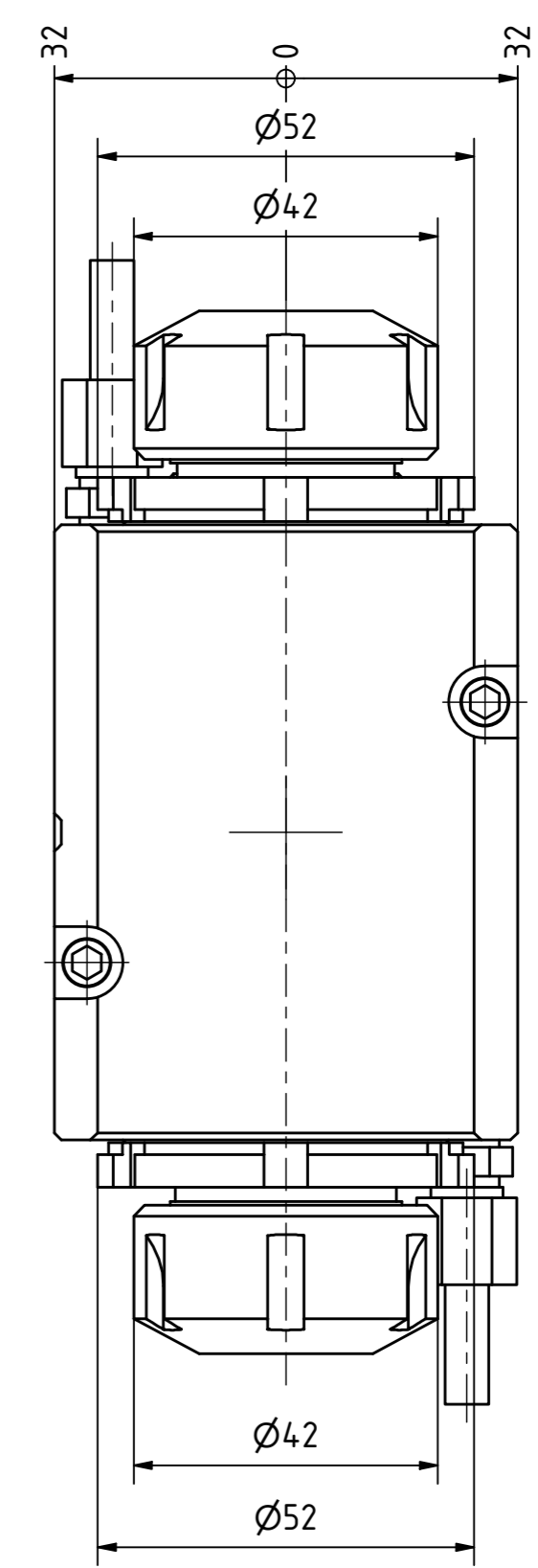

Copyright **EWS Tool Technologies**  
 Weitergabe und Vervielfältigung dieser Unterlage, Verwertung und Mitteilung ihres Inhalts nicht gestattet, soweit nicht ausdrücklich zugestanden. Zuwiderhandlungen verpflichten zu Schadenersatz.

Bemerkung - Note	Technische Daten - technical data Weight = 4,630 [kg] Torque max. (M1/M2) = 25 / 25   25 [Nm] Speed max. (n1/n2) = 8000 / 8000   8000 [1/min] Gear ratio (i)=n1:n2 = 1:1   1:1	Benennung - Title <b>Radial Bohr und Fräskopf</b> <i>Radial drilling and milling head</i>	 EWS Weigle GmbH & Co. KG Maybachstr. 1 D-73066 Uhingen www.ews-tool.de Nr. - No. <b>60.3025LDCTXRL</b>	Technische Änderungen vorbehalten! Subject to technical modifications! IDENT: DEWS113983 REV: -/C MNR. <b>146434</b>	
------------------	--	---	---	---	--