

Spannzange / collet ER20 DIN6499
Spannbereich / clamping range: 1,0 - 13,0

Gewindebohrzange / tapping collet
ET-1-20 M2-M6

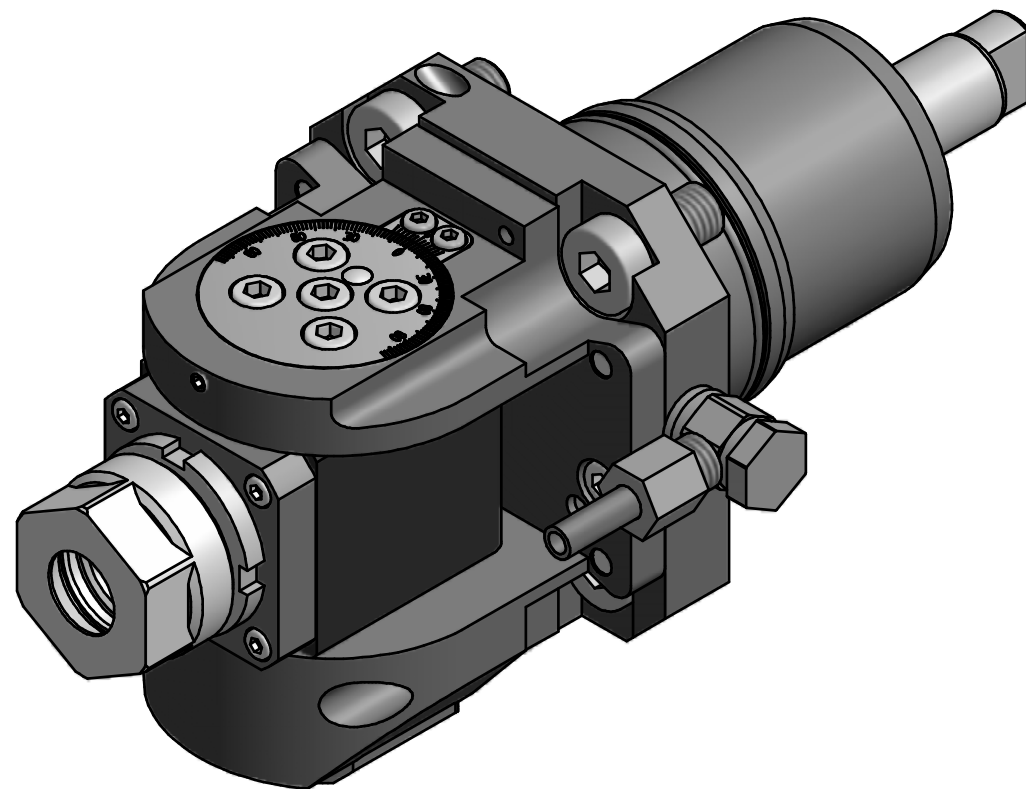

The swingdiameter of the toolholder is limited depending on angle attitude and tool length. Please check your machining operation.

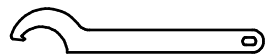

Hakenschlüssel
mit Nase
Hook wrench with
nose end
DIN1810 A 34x36

Copyright **EWS Tool Technologies**
Weitergabe und Vervielfaeltigung dieser Unterlage,
Verwertung und Mitteilung ihres Inhalts nicht
gestattet, soweit nicht ausdrecklich zugestanden.
Zuwiderhandlungen verpflichten zu Schadenersatz.

Bemerkung - Note

Technische Daten - technical data

Benennung - Title

M1 / M2 = 16 / 16 Nm
n1 / n2 = 6000 / 6000 1/min
i (N1:N2) = 1:1

Schwenkkopf
Swivel head

name	date
Sigel	26.02.2013

 **EWS** Weigete GmbH & Co. KG
 Maybachstr. 1
 D-73066 Uhingen
 Tel. +49(0)7161/93040-100

Technische Aenderungen vorbehalten! Subject to technical modifications!	
Nr.	63.5520WT250BMT
MNR: 146397	IDENT: D-EWS-132577 -

DIN A3

Blatt - page 1 (1)