

Doppelverzahnung Lizenz Traub
double tooth system licence Traub

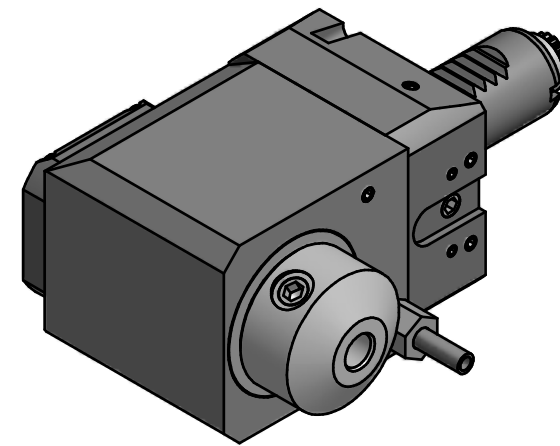
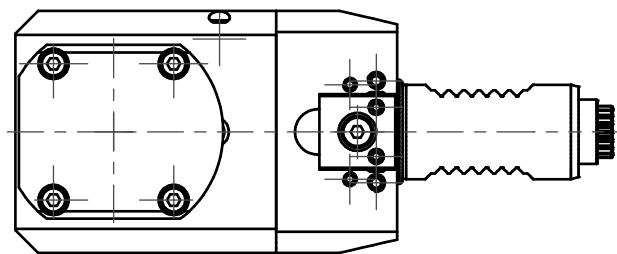

Copyright **EWS Tool Technologies**
 Weitergabe und Vervielfaeltigung dieser Unterlage,
 Verwertung und Mitteilung ihres Inhalts nicht
 gestattet, soweit nicht ausdrecklich zugestanden.
 Zuwiderhandlungen verpflichten zu Schadenersatz.

Bemerkung - Note

Technische Daten - technical data

Benennung - Title

M1 / M2 = 25 / 25 Nm
 n1 / n2 = 8000 / 8000 1/min
 i (N1:N2) = 1:1

Radial Bohr und Fräskopf
Radial drilling and milling head

	name	date
drawing	Kratschmann	14.11.2006

EWS EWS Weigete GmbH & Co. KG
 Maybachstr. 1
 D-73066 Uhingen
 Tel. +49(0)7161/93040-100

Technische Aenderungen vorbehalten!
Subject to technical modifications!

Nr.
60.2510WNL5480RL

MNR: 115405 IDENT: D-EWS-003057 A Blatt - page 1 (1)



DIN A3