

Spannzange / collet ER25 DIN6499  
Spannbereich / clamping range: 1,0 - 16,0

Gewindebohrzange / tapping collet  
ET-1-25 M3-M10

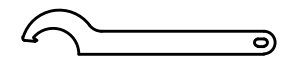

Hakenschlüssel  
mit Nase  
Hook wrench with  
nose end  
DIN1810 A 40x42

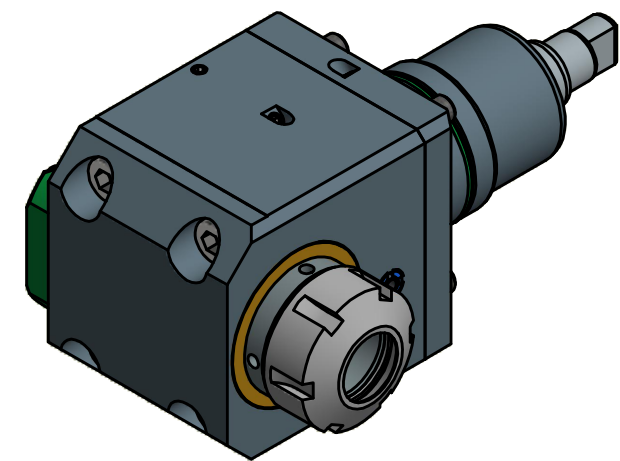
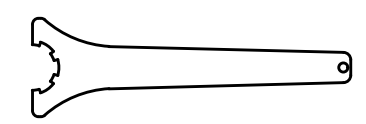

Spannzangenschlüssel  
Clamping wrench  
225

Copyright **EWS Tool Technologies**  
Weitergabe und Vervielfältigung dieser Unterlage,  
Verwertung und Mitteilung ihres Inhalts nicht  
gestattet, soweit nicht ausdrücklich zugestanden.  
Zuwendungen verpflichten zu Schadenersatz.

Bemerkung - Note

Technische Daten - technical data

Weight	= 3.778 [kg]
Torque max. (M1/M2)	= 25 / 25 [Nm]
Speed max. (n1/n2)	= 6000 / 6000 [1/min]
Gear ratio (i)=n1:n2	= 1:1

Benennung - Title

**Radial Bohr und Fräskopf**  
**Radial drilling and milling head**

**EWS** Tool Technologies  
EWS Weigele GmbH & Co. KG  
Maybachstr. 1  
D-73066 Utingen  
www.ews-tools.de

Nr. - No.  
**60.4425NTY3**

Technische Änderungen vorbehalten!  
Subject to technical modifications!

IDENT: DEWS126640

REV: -/B

MNR.  
**144920**

