

82 max.
78,5 min.

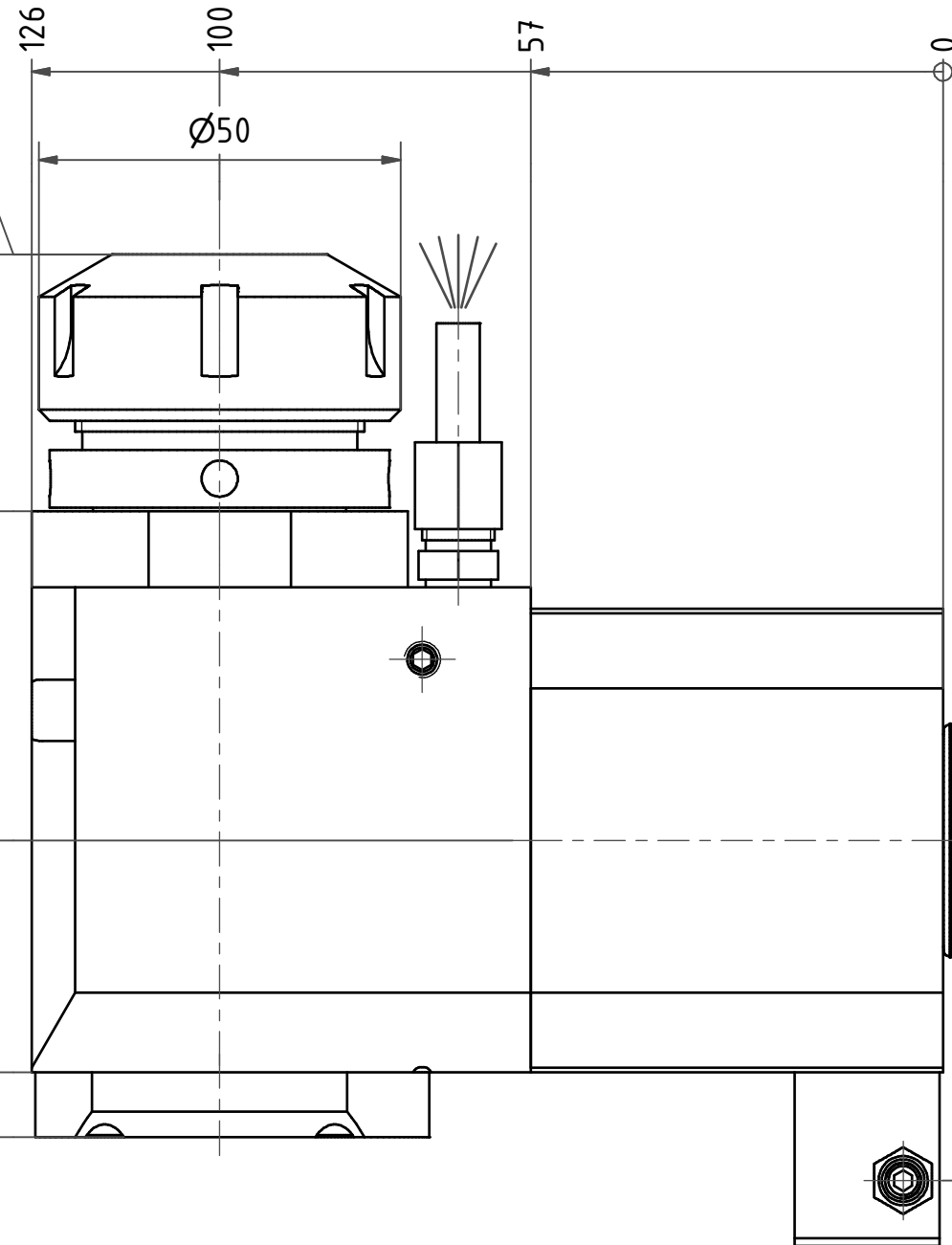

Spannzange / collet ER32 DIN6499
Spannbereich / clamping range: 2,0 - 20,0

Gewindebohrzange / tapping collet
ET-1-32 M5-M12

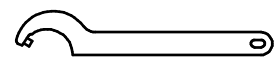
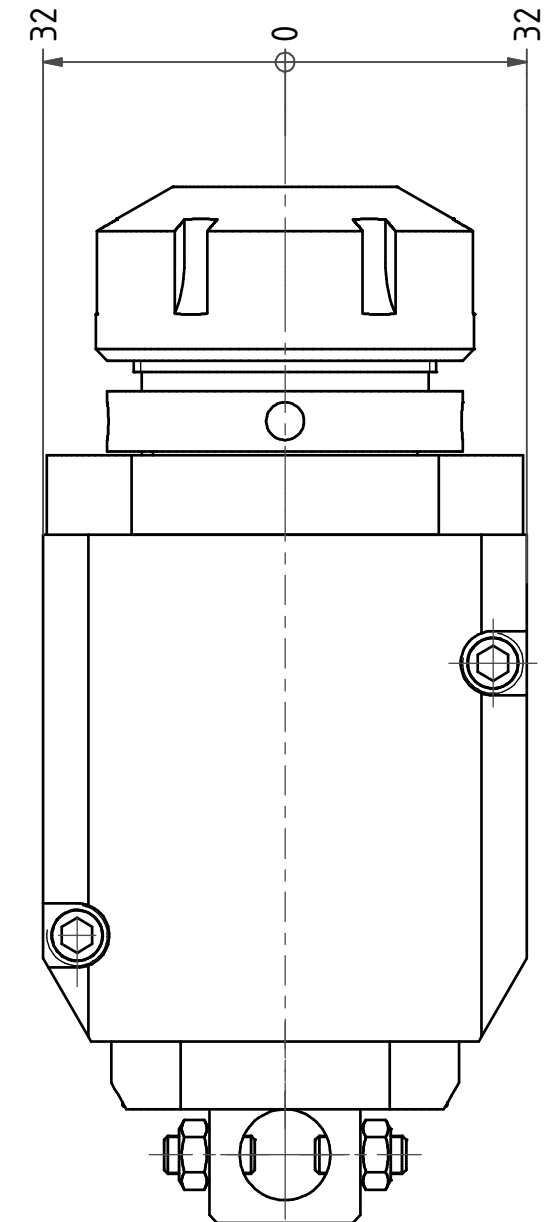
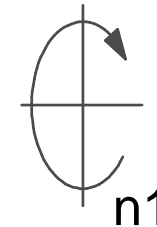

Hakenschlüssel
mit Zapfen
Hook wrench
with fixed pin
DIN1810 B 45x50

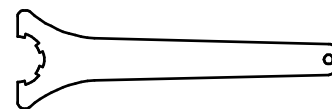

Spannzangenschlüssel
Clamping wrench
232

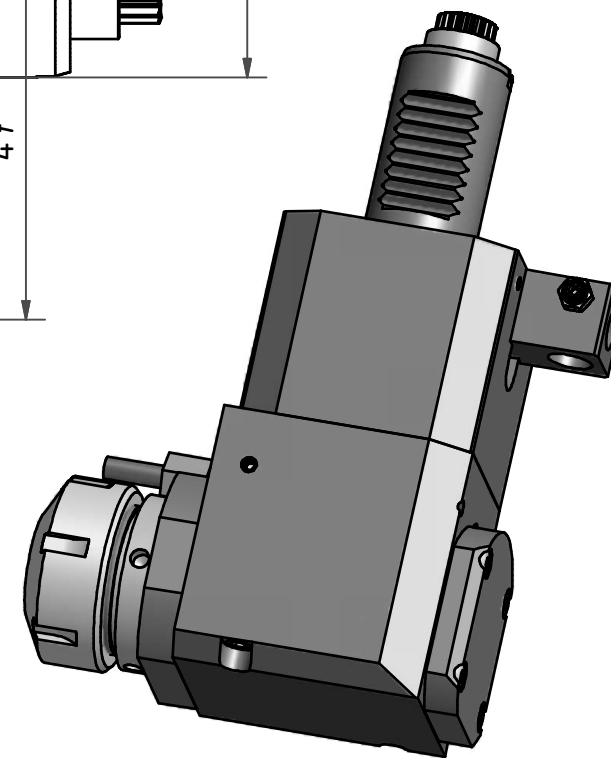

Copyright **EWS Tool Technologies**
Weitergabe und Vervielfältigung dieser Unterlage,
Verwertung und Mitteilung ihres Inhalts nicht
gestattet, soweit nicht ausdrücklich zugestanden.
Zu widerhandlungen verpflichten zu Schadenersatz.

Bemerkung - Note

Technische Daten - technical data

Benennung - Title

M1 / M2 = 20 / 40 Nm
n1 / n2 = 6000 / 3000 1/min
i (N1:N2) = 2:1

Radial Bohr und Fräskopf
Radial drilling and milling head

name	date
Theiss	22.02.2010

EWS Weigle GmbH & Co. KG
Maybachstr. 1
D-73066 Uhingen
Tel. +49(0)7161/93040-10
Tool Technologies

Technische Änderungen vorbehalten! Subject to technical modifications!	
Nr.	60.3032LCTXLI2
File:	D-EWS-084947-.idw
Blatt - page 1 (1)	

DIN A3