

Doppelverzahnung Lizenz Traub
double tooth system licence Traub

Hakenschlüssel
 mit Zapfen
*Hook wrench
 with fixed pin*
 DIN1810 B 40x42

Spannzange / collet ER20 DIN6499
 Spannbereich / clamping range: 1,0 - 13,0

Gewindebohrzange / tapping collet
 ET-1-20 M2-M6

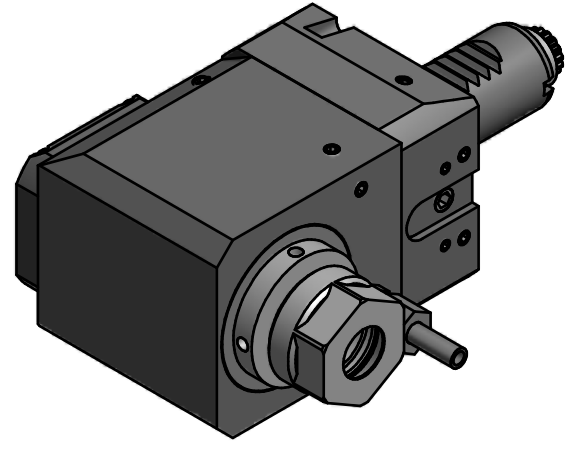
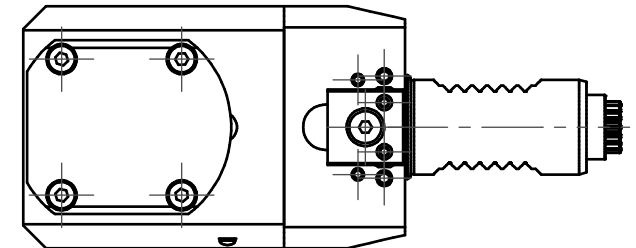

Copyright **EWS Tool Technologies**
 Weitergabe und Vervielfaeltigung dieser Unterlage,
 Verwertung und Mitteilung ihres Inhalts nicht
 gestattet, soweit nicht ausdrecklich zugestanden.
 Zuwiderhandlungen verpflichten zu Schadenersatz.

Bemerkung - Note 	Technische Daten - technical data M1 / M2 = 25 / 25 Nm n1 / n2 = 8000 / 8000 1/min i (N1:N2) = 1:1	Benennung - Title Radial Bohr und Fräskopf <i>Radial drilling and milling head</i>	<table border="1"> <tr> <td>name</td> <td>date</td> </tr> <tr> <td>Kratschmann</td> <td>14.11.2006</td> </tr> </table> EWS EWS Weigete GmbH & Co. KG Maybachstr. 1 D-73066 Uhingen Tel. +49(0)7161/93040-100	name	date	Kratschmann	14.11.2006	Technische Aenderungen vorbehalten! <i>Subject to technical modifications!</i> Nr. 60.2520L5480RL MNR: 113091 IDENT: D-EWS-003121 A Blatt - page 1 (1)
name	date							
Kratschmann	14.11.2006							