

Spannzange / collet ER32 DIN6499
 Spannbereich / clamping range: 2,0 - 20,0

Gewindebohrzange / tapping collet
 ET-1-32 M5-M12

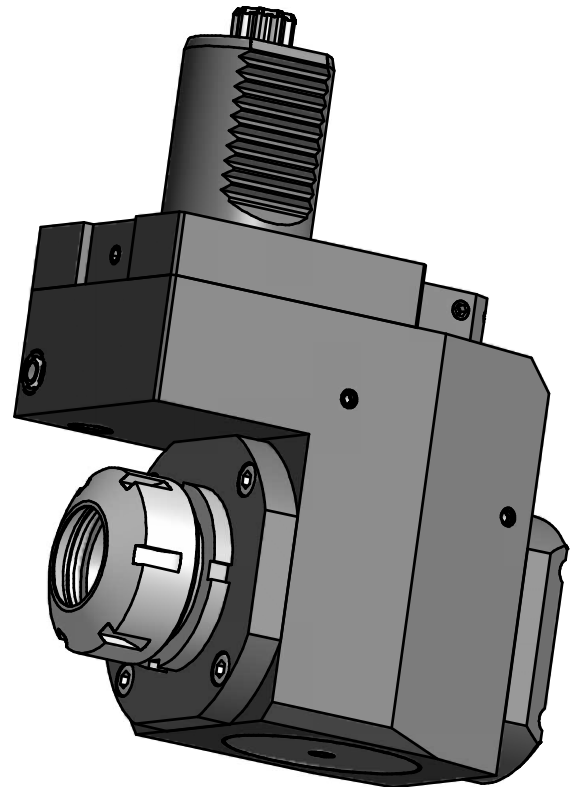
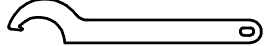
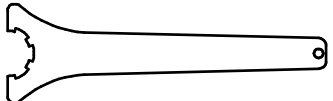

 Hakenschlüssel mit Nase
 Hook wrench with nose end
 DIN1810 A 45x50

 Spannzangenschlüssel
 Clamping wrench
 232

Copyright **EWS Tool Technologies**
 Weitergabe und Vervielfältigung dieser Unterlage,
 Verwertung und Mitteilung ihres Inhalts nicht
 gestattet, soweit nicht ausdrücklich zugestanden.
 Zuwiderhandlungen verpflichten zu Schadenersatz.

Bemerkung - Note	Technische Daten - technical data M1 / M2 = 50 / 50 Nm n1 / n2 = 6000 / 6000 1/min i (N1:N2) = 1:1	Benennung - Title Radial Bohr und Fräskopf. zurückges Radial drill. and mill. head offset	<table border="1"> <tr> <th>name</th> <th>date</th> </tr> <tr> <td>drawing</td> <td>15.02.2007</td> </tr> </table>	name	date	drawing	15.02.2007	Technische Aenderungen vorbehalten! Subject to technical modifications! Nr. 80.40325482L	 DIN A3
name	date								
drawing	15.02.2007								
MNR: 113059		IDENT: D-EWS-002377 -		Blatt - page 1 (1)					