

Spannzange / collet ER25 DIN6499
 Spannbereich / clamping range: 1,0 - 16,0

 Hakenschlüssel
 mit Zapfen
 Hook wrench
 with fixed pin
 DIN1810 B 45x50

 Spannzangenschlüssel
 Clamping wrench
 225

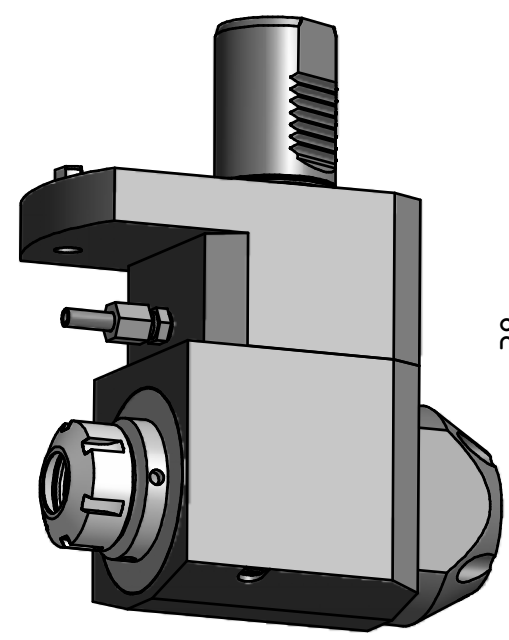

Innen- und Aussenkuehlung / Inside and outside coolant supply
 Kein Trockenlauf / No dry run
 Kuehlmittelfiltrierung 50μ / coolant filtration 50μ

Copyright **EWS Tool Technologies**
 Weitergabe und Vervielfaeltigung dieser Unterlage,
 Verwertung und Mitteilung ihres Inhalts nicht
 gestattet, soweit nicht ausdruuecklich zugestanden.
 Zuwiderhandlungen verpflichten zu Schadenersatz.

Bemerkung - Note Nicht ohne Kuehlmittel betreiben! Not for use without coolant-fluid!	Technische Daten - technical data M1 / M2 = 50 / 50 Nm n1 / n2 = 6000 / 6000 1/min i (N1:N2) = 1:1 pmax = 70 bar	Benennung - Title Radial Bohr und Fräskopf <i>Radial drilling and milling head</i>	name Kratschmann	date 12.11.2008	Technische Aenderungen vorbehalten! Subject to technical modifications!
			drawing		
			Weigele GmbH & Co. KG Maybachstr. 1 D-73066 Uehingen Tel. +49(0)7161/93040-10		DIN A3
			File: D-EWS-068654.idw		Blatt - page 1 (1)