

Spannzange / collet ER50 DIN6499  
 Spannbereich / clamping range: 6,0 - 34,0

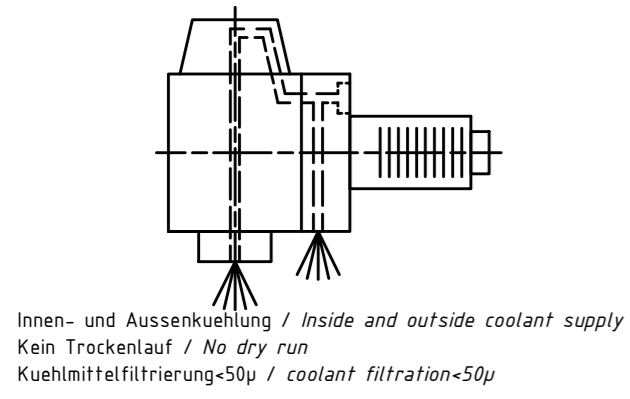
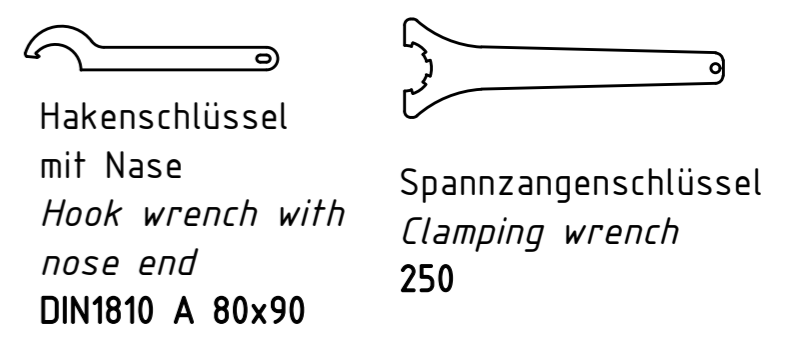

<p>Bemerkung - Note          Nicht ohne Kuehlmittel betreiben!          Not for use without coolant-fluid!</p>	<p>Technische Daten - technical data          Weight = 23.684 [kg]          Torque max. (M1/M2) = 100 / 100 [Nm]          Speed max. (n1/n2) = 4000 / 4000 [1/min]          Gear ratio (i)=n1:n2 = 1:1          Pressure (pmax) = 70 [bar]</p>	<p>Benennung - Title  <b>Radial Bohr und Fräskopf</b>  <b>Radial drilling and milling head</b></p>	<p><b>EWS</b> Tool Technologies          EWS Weigle GmbH &amp; Co. KG          Maybachstr. 1          D-73066 Uhlingen          www.ews-tool.de</p>	<p>Technische Aenderungen vorbehalten!          Subject to technical modifications!          IDENT: DEWS132890          REV: -/B          MNR.  <b>144985</b></p>	<p><b>QR</b></p>
--	--	--	---	---	------------------

Copyright **EWS Tool Technologies**  
 Weitergabe und Vervielfaeltigung dieser Unterlage,  
 Verwertung und Mitteilung ihres Inhalts nicht  
 gestattet, soweit nicht ausdrecklich zugestanden.  
 Zuwiderhandlungen verpflichten zu Schadenersatz.