

Spannzange / collet ER32 DIN6499  
 Spannungsbereich / clamping range: 2,0 - 20,0

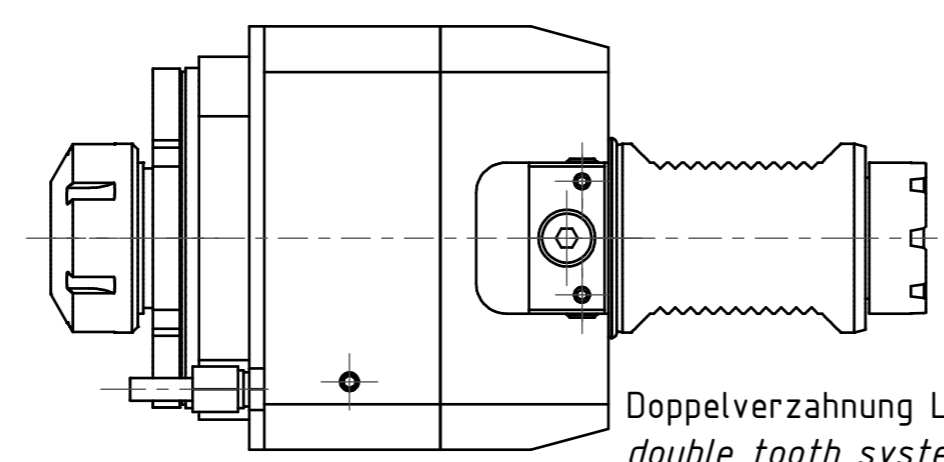

Gewindebohrzange / tapping collet  
 ET-1-32 M5-M12

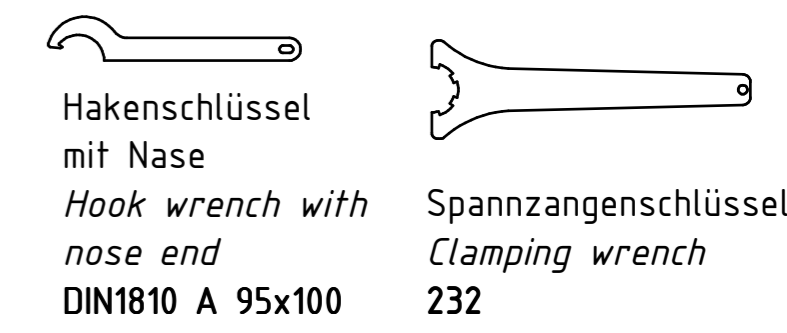
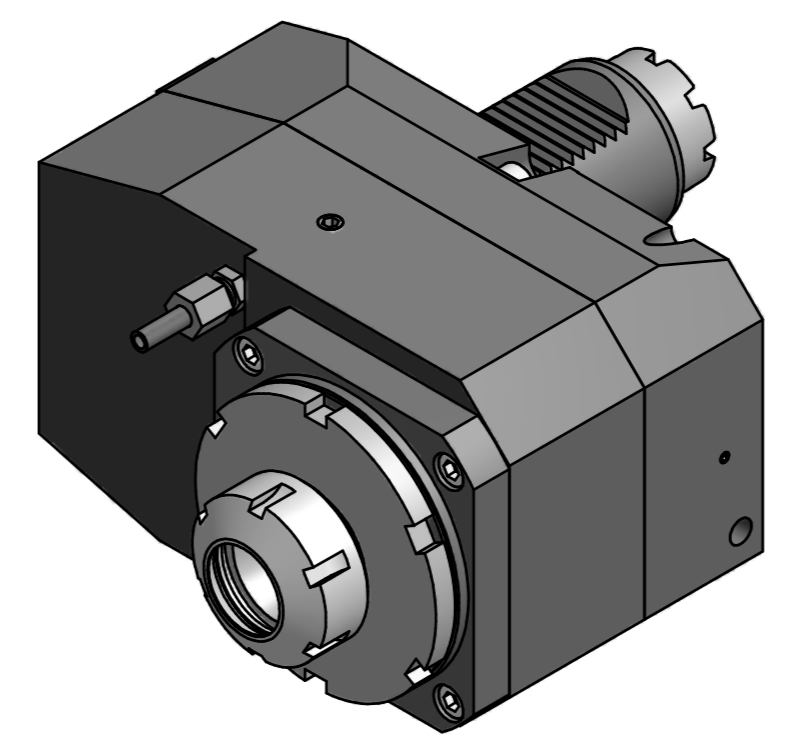

Doppelverzahnung Lizenz Traub  
 double tooth system licence Traub

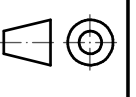

Copyright **EWS Tool Technologies**  
 Weitergabe und Vervielfältigung dieser Unterlage, Verwertung und Mitteilung ihres Inhalts nicht gestattet, soweit nicht ausdrücklich zugestanden. Zuwiderhandlungen verpflichten zu Schadenersatz.

Bemerkung - Note	Technische Daten - technical data $M_1 / M_2 = 100 / 50 \text{ Nm}$ $n_1 / n_2 = 4000 / 8000 \text{ 1/min}$ $i (N_1:N_2) = 1:2$	Benennung - Title <b>Axial Bohr u. Fräskopf achsversetzt</b> <b>Ax. drill. and mill. head offset</b>	name	date	Technische Änderungen vorbehalten! <i>Subject to technical modifications!</i>	 DIN A2	
			drawing	Theiss			03.08.2015
			 EWS Weigte GmbH & Co. KG Maybachstr. 1 D-72096 Ulmringen Tel. +49(0)7161/93040-100		MNR: 114991	IDENT: D-EWS-184329 -	Blatt - page 1 (1)