

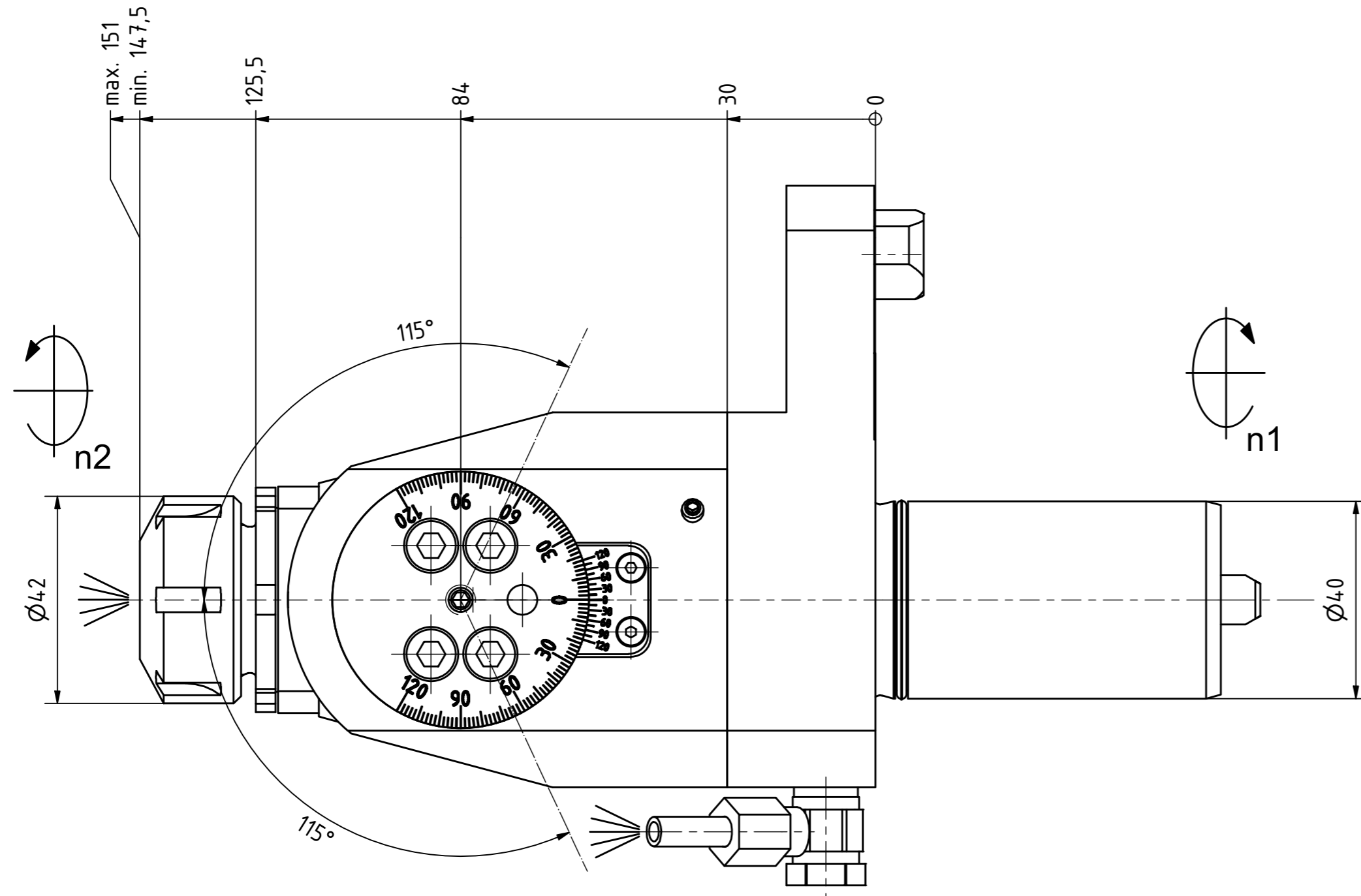

Ceramic Seal



Tech Details



Schwenkbereich $\pm 115^\circ$
Swivel area $\pm 115^\circ$

Spannzange / collet ER25 DIN6499
Spannbereich / clamping range: 1,0 - 16,0

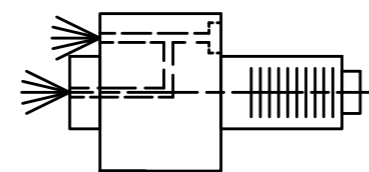
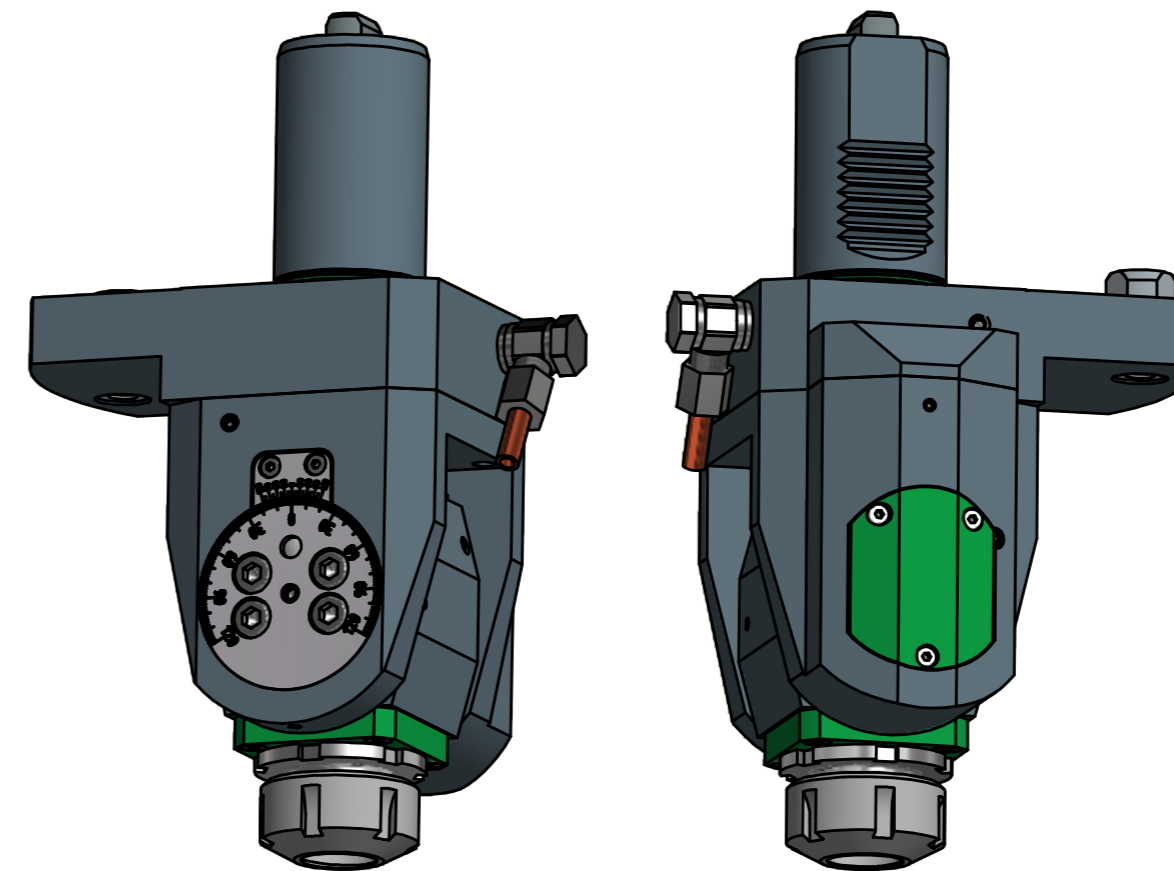
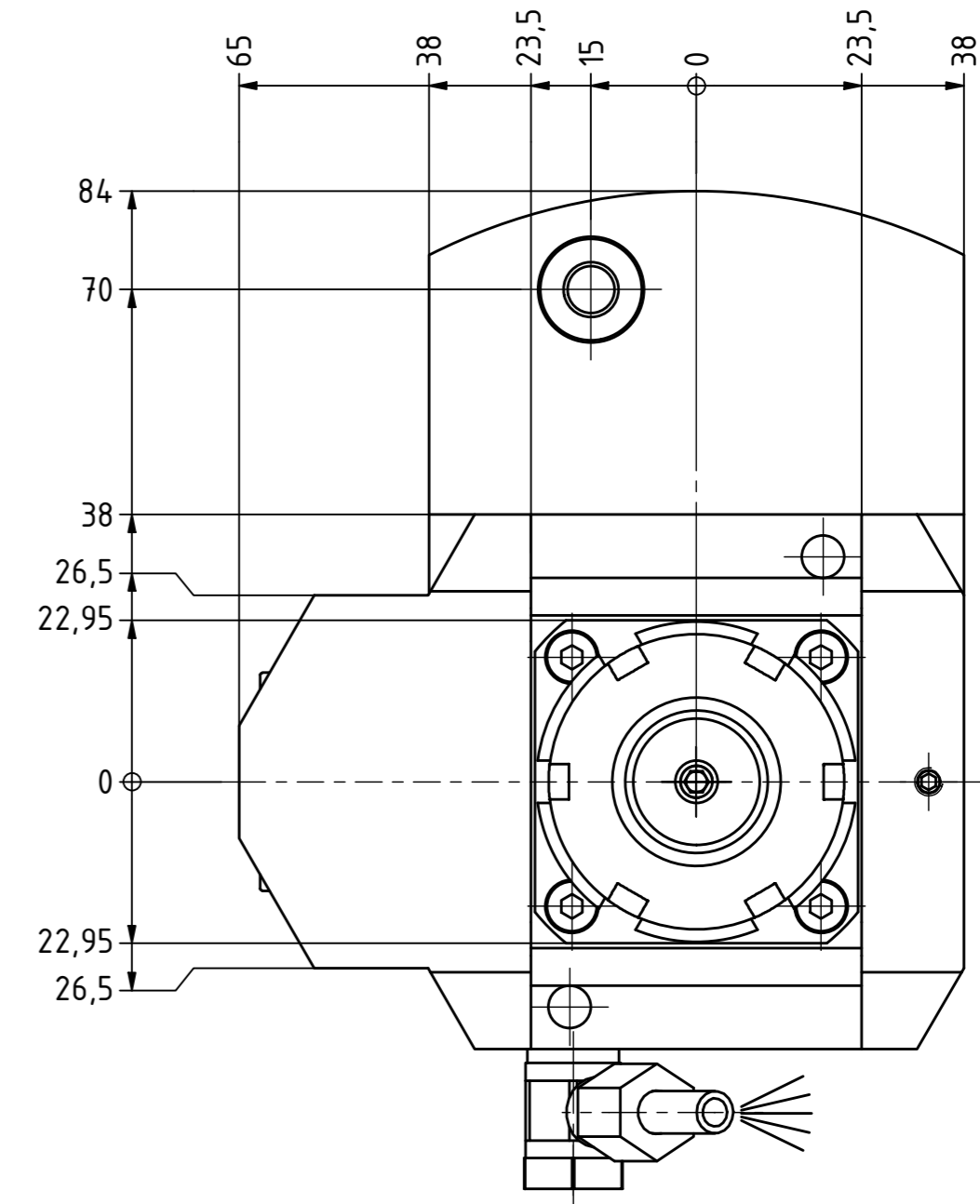

Innen- und Aussenkuehlung / Inside and outside coolant supply
Kuehlmittelfiltrierung+50µ / coolant filtration+50µ



Hakenschlüssel
mit Nase

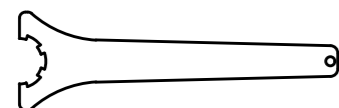

Hook wrench with
nose end
DIN1810 A 45x50
Spannzangenschlüssel
Clamping wrench
225

Bemerkung - Note
Für Trockenlauf geeignet!
Use without coolant fluid allowed!

Technische Daten - technical data
Weight = 6.079 [kg]
Torque max. (M1/M2) = 20 / 20 [Nm]
Speed max. (n1/n2) = 6000 / 6000 [1/min]
Gear ratio (i)=n1:n2 = 1:1
Pressure (pmax) = 70 [bar]

Benennung - Title
Schwenkkopf
Swivel head



EWS Weigle GmbH & Co. KG
Maybachstr. 1
D-73066 Uhlingen
www.ews-tools.de

Technische Änderungen vorbehalten!
Subject to technical modifications!

IDENT: DEWS137163

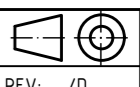

REV: -/D

Nr. - No.
63.4025KMP620IKD

MNR.
144436



Copyright EWS Tool Technologies
Weitergabe und Vervielfältigung dieser Unterlage,
Verwertung und Mitteilung ihres Inhalts nicht
gestattet, soweit nicht ausdrücklich zugestanden.
Zuwendungen verpflichten zu Schadenersatz.