

Schwenkbereich $\pm 115^\circ$
Swivel area $\pm 115^\circ$

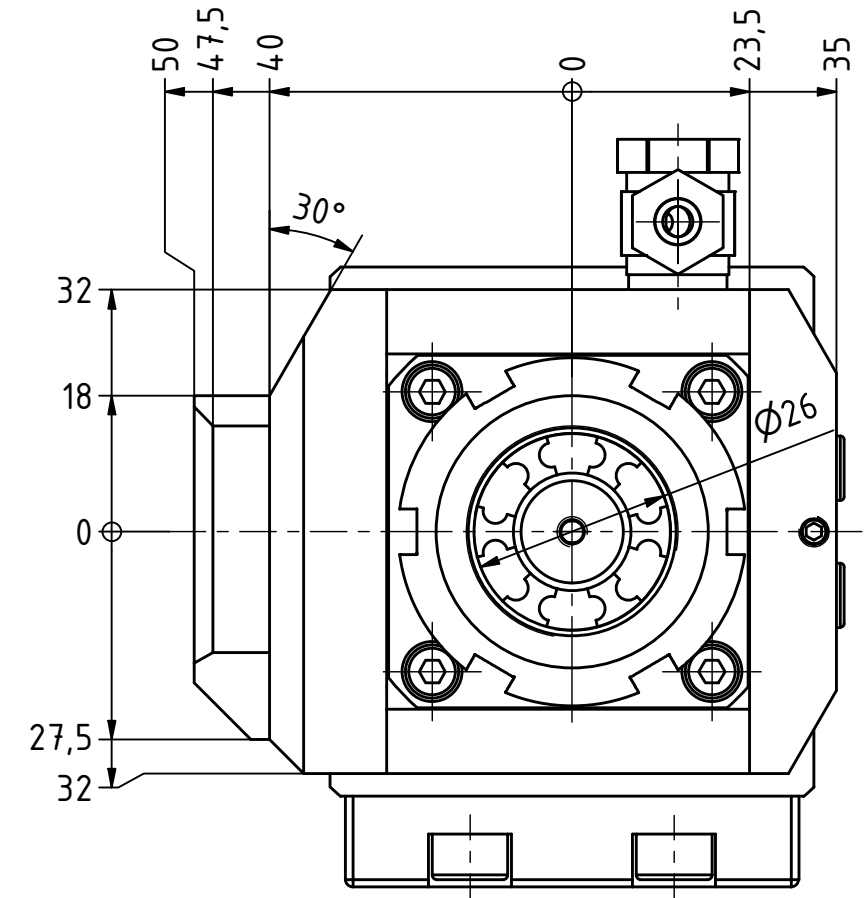

Spannzange / collet ER20 DIN6499
Spannbereich / clamping range: 1,0 - 13,0

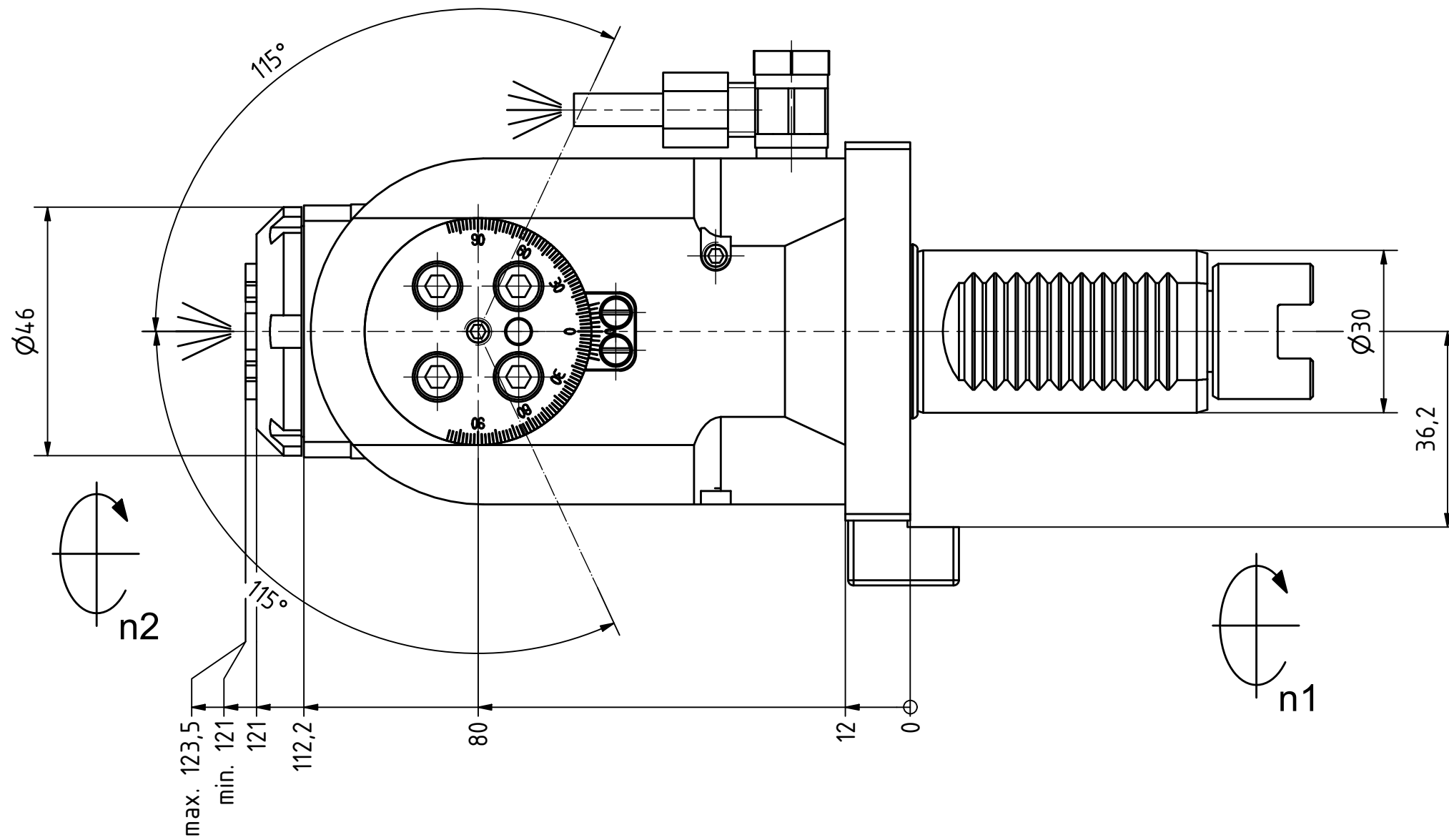
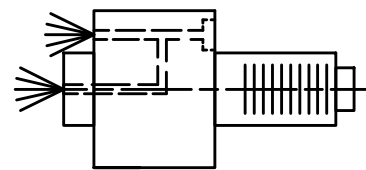

Innen- und Aussenkuehlung / Inside and outside coolant supply
Kuehlmittelfiltrierung $< 50\mu$ / coolant filtration $< 50\mu$

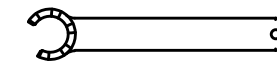
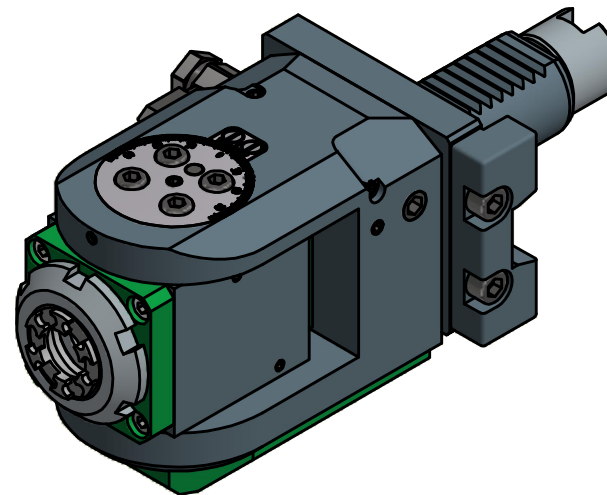

Spannzangenschlüssel für innenliegende Mutter
Clamping wrench for internal collet
220AX

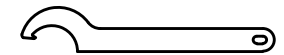

Hakenschlüssel mit Nase
Hook wrench with nose end
DIN1810 A 45x50

Copyright **EWS Tool Technologies**
Weitergabe und Vervielfaeltigung dieser Unterlage, Verwertung und Mitteilung ihres Inhalts nicht gestattet, soweit nicht ausdrucklich zugestanden. Zuwiderhandlungen verpflichten zu Schadenersatz.

Bemerkung - Note
Für Trockenlauf geeignet!
Use without coolant fluid allowed!

Technische Daten - technical data
Weight = 3.804 [kg]
Torque max. (M1/M2) = 16 / 16 [Nm]
Speed max. (n1/n2) = 8000 / 8000 [1/min]
Gear ratio (i)=n1:n2 = 1:1
Pressure (pmax) = 70 [bar]

Benennung - Title
Schwenkkopf
Swivel head

EWS Tool Technologies
EWS Weigle GmbH & Co. KG
Maybachstr. 1
D-73066 Uthingen
www.ews-tools.de

Technische Aenderungen vorbehalten!
Subject to technical modifications!

IDENT: D-EWS-067638

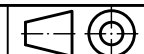

REV: -/C

Nr. - No.

63.3020G300IKDVIM

MNR.

144620

QR